

Alexandria[®] X-2



Wilson Audio® is a registered trademark of Wilson Audio Specialties, Inc.

Cub®, Sophia®, WATT/Puppy®, MAXX®, and Alexandria® are registered trademarks of Wilson Audio Specialties, Inc.

WilsonGloss™, Duette by Wilson Audio™, WATCH Center™, WATCH Surround™, and WATCH Dog™ are trademarks of Wilson Audio Specialties, Inc.

This manual was produced by the Wilson Audio Engineering and the Sales and Marketing Department. The information contained herein is subject to change without notice. Current Revision 2.0. If you are in need of a more recent manual, please contact your dealer.

The information in this manual is the sole property of Wilson Audio Specialties, Inc. Any reproduction, in whole or in part, without the express written permission of Wilson Audio Specialties, Inc., is prohibited. No material contained herein may be transmitted in any form or by any means, electronic or mechanical, for any purpose, without the express written permission of Wilson Audio Specialties, Inc.

CE

SECTION 1 – INTRODUCTION 7

SECTION 1.1 – INTRODUCTION 9

 ASPHERICAL PROPAGATION DELAY 10

SECTION 2 – IN YOUR ROOM 13

SECTION 2.1 – ROOM ACOUSTICS..... 15

 FINAL LISTENING ROOM SETUP (VOICING)..... 15

 ZONE OF NEUTRALITY..... 15

SECTION 2.2 – ROOM REFLECTIONS 17

 SLAP ECHO..... 17

 STANDING WAVES 20

 COMB FILTER EFFECT..... 21

SECTION 2.3 – RESONANCES 22

 STRUCTURAL RESONANCE..... 22

 VOLUME RESONANCE..... 22

SECTION 2.4 – YOUR ROOM 23

 ROOM SHAPES 23

 ALEXANDRIA X-2 SERIES 2 IN A DEDICATED HOME THEATER 25

 SPEAKER PLACEMENT VERSUS LISTENING POSITION 25

 SPEAKER ORIENTATION 26

 SUMMARY 27

SECTION 3 – UNCRATING THE ALEXANDRIA..... 29

SECTION 3.1 – UNCRATING THE ALEXANDRIA 31

 INITIAL CHECK 31

 TOOLS REQUIRED 31

 UNCRATING THE WOOFER MODULES..... 31

 UNPACKING THE WOOFER 32

UNCRATING THE ASPHERICAL WINGS.....	32
UNCRATING THE UPPER ARRAY MODULES.....	33
UNCRATING THE CROSSOVER COVER.....	33
CRATE CONTENTS CHECKLIST.....	34
SECTION 4 – ASSEMBLING YOUR ALEXANDRIAS.....	37
SECTION 4.1 – INITIAL ASSEMBLY.....	39
RE-ATTACH PROPAGATION DELAY PLATE.....	40
SECTION 4.2 – GEOMETRIC TIME DOMAIN ALIGNMENT.....	42
MATERIALS REQUIRED:.....	42
PROPAGATION DELAY ALIGNMENT.....	42
ROOM SETUP.....	43
ALIGNMENT PROCEDURE.....	43
IDENTIFICATION OF ALIGNMENT SPIKES AND TETHER BOLTS.....	43
SECTION 4.3 – MOUNTING UPPER ARRAY MODULES.....	45
MATERIALS REQUIRED.....	45
MOUNTING PROCEDURE.....	45
INSTALL THE LOWER MIDRANGE MODULE (LMRM).....	46
SECTION 4.4 – CONNECTING THE UPPER MODULES’ SIGNAL CABLE.....	47
SECTION 4.5 – LOCKING DOWN THE UPPER MODULES.....	50
MATERIALS REQUIRED.....	50
INSTALLING THE TETHER BOLTS.....	51
SECTION 4.6 – SPIKE INSTALLATION.....	51
SECTION 4.7 – USING THE LIFT TO INSTALL SPIKES.....	53
MATERIALS REQUIRED.....	53
INSTALLATION PROCEDURE.....	54
LEVELING THE ALEXANDRIA.....	56

SECTION 4.8 – EXTENSION SPIKES 57

SECTION 4.9 – INSTALLING THE BACK COVERS..... 57

SECTION 4.10 – RESISTORS 57

 MIDRANGE PHASE RESISTORS 58

 WOOFER DAMPING RESISTOR..... 58

SECTION 4.11 – BREAK-IN PERIOD..... 59

SECTION 5 – CARE OF ALEXANDRIA X-2 61

SECTION 5.1 – CARE OF THE PAINTED FINISH 63

 CARE OF THE GRILLES..... 64

SECTION 5.2 – ENCLOSURE CONSTRUCTION 65

 MATERIAL 65

 ADHESIVE..... 65

 CONCLUSION 66

SECTION 6 – TROUBLESHOOTING 67

SECTION 7 – SYSTEM SPECIFICATIONS 73

SECTION 7.1 – SPECIFICATIONS:..... 75

SECTION 7.2 ALEXANDRIA X-2 DIMENSIONS 76

SECTION 8 – PROPAGATION DELAY TABLES 77

SECTION 9 – WARRANTY INFORMATION 89

SECTION 9.0 – WARRANTY INFORMATION..... 91

 LIMITED WARRANTY 91

 CONDITIONS 91

 REMEDY..... 92

 WARRANTY LIMITED TO ORIGINAL PURCHASER 92

 DEMONSTRATION EQUIPMENT 93

MISCELLANEOUS..... 93



SECTION 1 - INTRODUCTION



Section 1.1 – Introduction

From all of us at Wilson Audio Specialties — thank you for purchasing the Alexandria® X-2 Series 2 loudspeaker. The information contained within the pages of this manual will inform and instruct you as to how you may enhance and prolong the enjoyment of your Alexandria loudspeaker.

The original Alexandria was the fruition of a blank-slate approach to creating a new flagship loudspeaker for the real world. It introduced radically new technologies, such as Aspherical Propagation Delay™, and capitalized on the synergistic application of technologies perfected in the decade since the revolutionary X-1 Grand SLAMM® platform was introduced. Since that time, technologies introduced in the MAXX®, the WATT/Puppy®, and the Sophia® made it clear that it was time to revisit Alexandria.

Among the technical innovations of the Alexandria:

- All-new midrange driver developed specifically for the Series 2 Alexandria.
- New improved tweeter. Back wave interference has been reduced to the lowest levels yet.
- New crossovers potted in cases milled from “X” material. Microphonics and mechanical interference are greatly reduced through this aggressive strategy. Applying new technology in the realm of propagation delay jitter, the Alexandria Series 2 crossover is the most time coherent yet produced.
- New back cover for easy access. The single cover has been replaced by two, which attach with Wilson’s stainless steel pin hardware. A tempered glass window allows the crossover and resistors to be viewed with the cover in place.
- New resistor connector plate with reduced resonance and greater heat dissipation.

Aspherical Propagation Delay

A musical waveform is a complex overlay of frequencies, amplitudes, and phase relationships. With current technology, no single transducer can reproduce the full range of music at realistic sound pressure levels while maintaining consistent dispersion. The solution is the multiple driver array, with specific drivers dedicated to various portions of the frequency range. Multiple drivers introduce their own set of problems, however, chief among them the challenge of preserving the precise time relationships of the musical waveform.

The key to solving this problem lies in Wilson's innovative and patented Adjustable Propagation Delay technology, which employs movable modules that allow the individual adjustment of the drivers in the time domain. Using this technology, each driver's waveform propagation "matches up" with its neighbors' in such a way to create the sonic equivalent of a single point source. Certain other loudspeaker makers recognize the need to correctly align their drivers, but they do so for only one theoretical listening position.

The fact is, misalignment of the drivers by fractions of an inch will audibly degrade transient accuracy, soundstage height, depth,

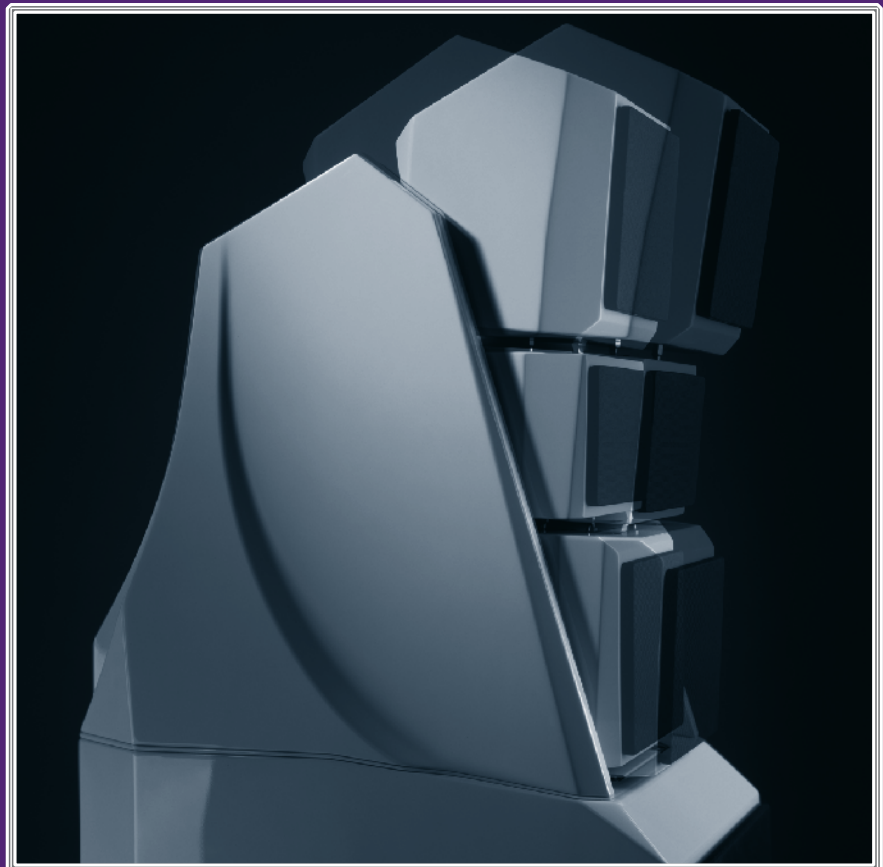

FIGURE 1 – ALEXANDRIA'S MODULES MOVE ASPHERICALLY TO CORRECT PROPAGATION DELAY

and width. Misalignment of the drivers will also introduce tonal anomalies that destroy the otherwise convincing “presence” of an instrument or a singer’s voice. Wilson’s solution for propagation delay correction has long set the standard for precise driver positioning in order to insure correct time alignment for a wide range of real room listening



FIGURE 2A - TYPICAL LOUDSPEAKERS EXHIBIT LESS THAN OPTIMUM PROPAGATION DELAY AND DISPERSION CHARACTERISTICS. THE SOUND QUALITY IS COMPROMISED FOR ALL LISTENERS IN ALL ROOMS.



FIGURE 2B - ASPHERICAL PROPAGATION DELAY OPTIMIZES DRIVER/ROOM INTERACTION FOR A VARIETY OF SITUATIONS. THIS PROVIDES CONSISTENTLY OPTIMIZED RESULTS IN A WIDE RANGE OF ROOMS AND LISTENING POSITIONS.



FIGURE 2 – ALEXANDRIA’S MODULES MOVE ASPHERICALLY TO CORRECT PROPAGATION DELAY

distances and ear heights.

The signature curves in Alexandria's cabinet are a further evolution of Wilson's philosophy that truly great forms follow a corresponding function. They are a visual metaphor for the solution Wilson Audio pioneered to address issues of phase coherence exacerbated by large speaker systems. Typical of the creative process, the solution itself came as a metaphor, or rather, an analogy to the field of optics and the design of wide-angle lenses. The means of maintaining edge-to-edge sharpness at both close and far focusing distances for a high quality wide-angle lens suggested a solution to the similar problem of time domain accuracy for large speaker systems at both near and far listening positions.

With Alexandria, Wilson Audio takes this concept a logical step further, addressing the issue of optimal driver dispersion in the large cabinet system. Ideal driver dispersion for both near and far listening positions requires the drivers be adjustable not only forward and back, but also able to rotate on their polar axes.

With Alexandria, for the first time ever, you and others you listen with, will hear your favorite recordings and soundtracks with true time coherency, full frequency range, unfettered dynamics, and vanishingly low distortion. The improvement in realism wrought by Alexandria X-2 Series 2 is delightfully revolutionary.

SECTION 2 - IN YOUR ROOM



Section 2.1 – Room Acoustics

You are surely excited about setting up your Alexandria X-2 Series 2 loudspeakers and doing some listening, but before you begin, we would like to discuss some of the important room acoustical information that will help you set up your loudspeakers properly.

Final Listening Room Setup (Voicing)

For a speaker system its size, the Series 2 Alexandria X-2 is unmatched in its ability to reproduce the musical event. It is truly state of the art. However, room acoustics and boundary interactions affect the sound of a loudspeaker to such a large degree that poor setup can seriously degrade your enjoyment of even the finest loudspeaker.

Therefore, we offer the following section, which will present some guidelines on room acoustics and their interactions with loudspeakers. While we will also outline some detailed suggestions on the setup of the Alexandrias, we strongly suggest that you have your local Wilson Audio dealer perform the final speaker “voicing” with you. Wilson dealers are specially trained in setting up Wilson loudspeakers and will ensure that you realize the full value of your purchase.

Zone of Neutrality

The “Zone of Neutrality” is an area in your room where the speakers will sound most natural. This location is where the speakers interact the least with adjacent room boundaries. It is important to have a clear working space while determining the Zone of Neutrality.

The following is a simple method to locate the Zone of Neutrality within your listening environment:

1. Stand against the wall BEHIND the location where you intend to position

your Alexandrias. Speaking in a moderately loud voice and at a constant volume, project your voice out into the room. Your voice will have an overly heavy, “chesty” quality because of your proximity to the rear wall.

2. While speaking, slowly move out into the room, progressing in a direction parallel to the sidewall. It is helpful to have another listener seated in the listening position to assist you during this process. Listen to how your voice “frees up” from the added bass energy imparted by the rear wall boundary. Also notice that your voice is quite spatially diffuse (to your assistant, your voice will sound spatially large and difficult to localize) as you begin to ease away from the rear wall.
3. At some point during your progression forward into the room, you will observe a sonic transition in your voice; it will sound more tonally correct and less spatially diffuse (your assistant can now precisely localize the exact origin of your voice). When you hear this transition, you have entered the inner edge of the Zone of Neutrality. Place a piece of tape on the floor to mark this location. Although it will vary from room to room, the zone in most rooms begins between two and a half to three feet from the rear wall.
4. Continue to walk slowly away from the rear wall. After some distance, usually one to two feet past the first piece of tape, you will begin to hear your voice lose focus and appear to reflect (echo) in front of you. This is caused by the return of the room’s boundary contribution; your voice is now interacting with the opposite wall. At the point where you begin to hear the reflected sound of your voice, you have reached the inner edge of the Zone of Neutrality. Place a piece of tape on the floor and mark this location. The distance between the “inner” and “outer” edge tape marks is usually between eight inches (for small, interactive rooms) and three feet (for large, more neutral rooms).
5. Now position yourself against the side wall perpendicular to the intended speaker location. Stand between the two tape marks. Using the same procedure as above, begin moving into the room toward the opposite sidewall, progressing between the two pieces of tape. As above, listen for the point

in the room where your voice transitions from bass-heavy and diffuse to neutral. Mark this point with tape. Continue your progression until there is an obvious interaction with the opposite wall in front of you and mark this point with tape. The four pieces of tape now form a rectangle that establishes the Zone of Neutrality for the loudspeaker located on that side of the room. Using the four marks as your guide, tape an outline to define the boundaries of the rectangle.

6. Repeat this process for each speaker location individually. These are your Zones of Neutrality, one for each channel.

Theoretically, the Zone of Neutrality for any room runs like a path, parallel to the walls all around the room. Adjacent to very large windows and open doors, the outer edge of the Zone of Neutrality moves closer to the wall and becomes wider. If you were to extend the inner and outer boundaries of the Zone for the sidewalls and the front wall (behind the speakers), they would intersect. After you complete this procedure for the other loudspeaker, you will now have two rectangles, one on the floor on either side of the room.

Note: The more reflective or “live” sounding the room is, the more difficult it will be to detect the changes in your voice; thus, you may have to repeat this process until the zones have been determined.

Section 2.2 – Room Reflections

Note: The following section contains general information on room acoustics and loudspeaker/room interaction. The concepts outlined below are equally relevant when dealing with multi-channel audio or home theater. The careful application of these concepts, as you evaluate the acoustical characteristics of your own room configuration, will allow you to optimize the performance of your Alexandrias.

Slap Echo

Probably the most obnoxious form of reflection is called “slap echo.” With slap-echo, primarily midrange and high frequency sounds reflect off of two parallel hard sur-

faces. The sound literally reverberates back and forth until it is finally dissipated over time. You can test for slap echo in any room by clapping your hands sharply in the middle of the room and listening for the characteristic sound of the echo in the midrange. Slap echo destroys the sound quality of a stereo system in two ways:

- It adds harshness to the upper midrange and treble by storing time-domain smearing energy.
- It destroys the delicate phase relationships, which help to establish an accurate soundstage.

Slap echo (see Figure 3) is a common acoustical problem in the typical domestic listening room because most of these rooms have walls with a hard, reflective nature, only

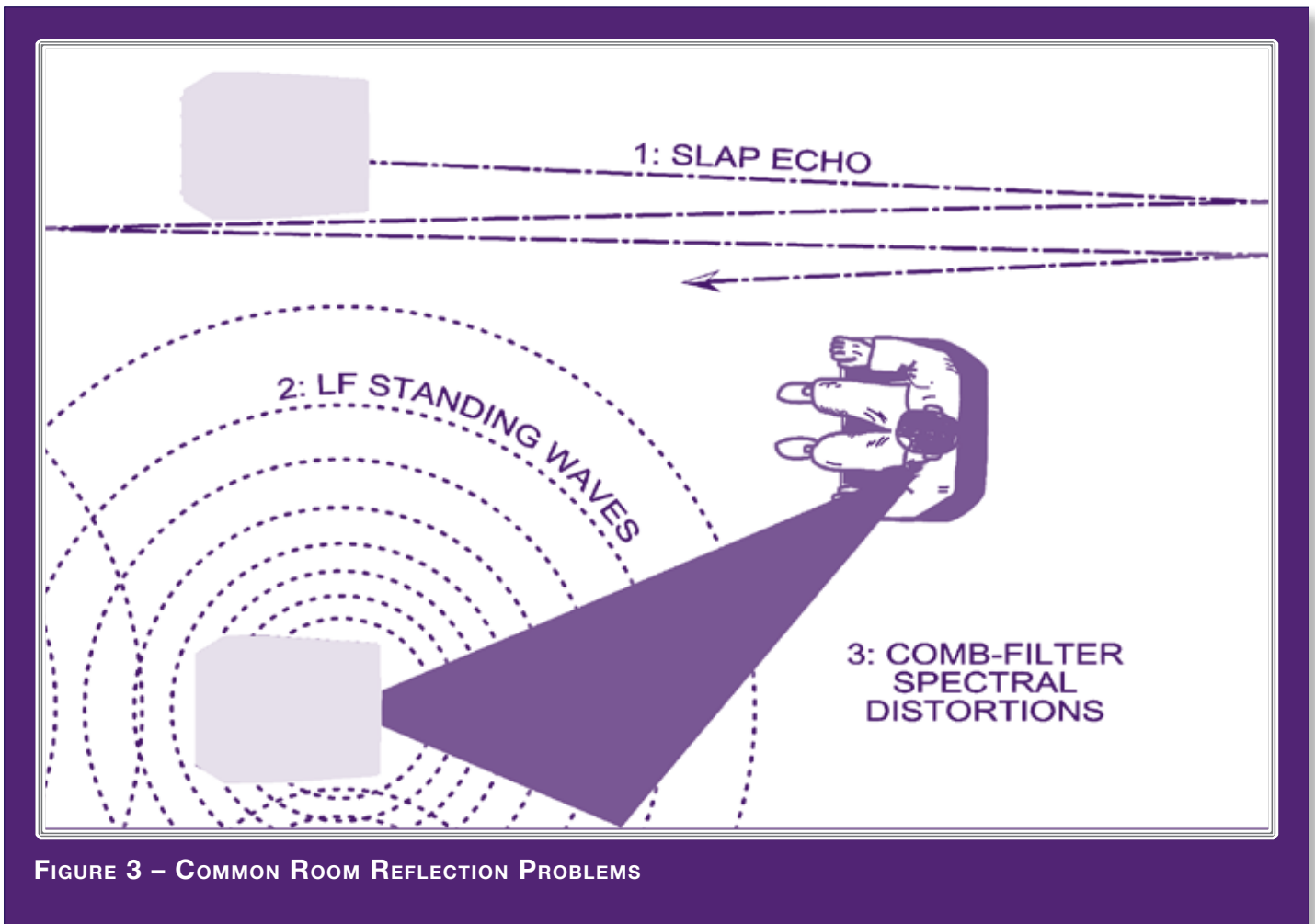

FIGURE 3 – COMMON ROOM REFLECTION PROBLEMS

occasionally interrupted by curtains, wall art, or drapes. The best (but least practical) solution to eliminate slap echo is nonparallel walls. This is because, rather than support slap-echo, nonparallel walls allow the sound to diffuse. This approach can be accounted for during the construction process. For existing rooms, slap echo can also be controlled entirely by the application of absorptive materials to the hard surfaces. These are absorptive materials that can be used to ameliorate slap echo:

- Illbruck Sonex®
- Air duct board
- Cork panels
- Large ceiling to floor drapes
- Carpeting to wall surfaces

In many domestic listening environments, heavy stuffed furnishings reduce slap echo somewhat. Unfortunately, their effectiveness is not predictable. Diffusers are sometimes also used to very good subjective effect, particularly in quite large rooms. Sound absorbent materials such as described above will alter the tonal characteristic of the room by making it sound “deader,” less “bright and alive,” and “quieter.” These changes usually make the room more pleasant for conversation, but sometimes render it too dull in the high frequencies to be musically involving. Soundtrack effects will be more localized. However, over-damping the room can render reproduced sound that is lacking in musical involvement and “aliveness.”

Diffusers, on the other hand, do not affect the tonal balance characteristic of the room as much. Placed properly, diffusers create a smoother and more open sound. Some diffusers, due to their construction, create narrow midrange peaks and suck-out the warmth region. Do not use diffusers on the wall behind the speakers or on the sidewalls

directly beside the speakers. It is our experience that all of these room treatment devices should be used judiciously.

Standing Waves

Another type of reflection phenomenon is “standing waves.” Standing waves cause the unnatural boosting or accentuation of certain frequencies, typically in the bass, to be found at certain discreet locations in the room. These locations differ according to room dimension and size. A room generating severe standing waves creates difficulty in setup. In these rooms, the speaker will sound radically different as it is moved around. The effects of standing waves on a loudspeaker’s performance are primarily in the areas listed.

- Tonal balance
- Resolution of low-level detail
- Soundstaging

Standing waves are more difficult to correct than slap echo because they tend to occur at a lower frequency. Absorbent materials, such as Illbruck Sonex®, are ineffective at controlling reflections in the bass region. Moving speakers about slightly in the room is, for most people, their only control over standing waves. Sometimes a change of placement of as little as two or three inches can dramatically alter the tonal balance of a small system.

Fortunately, minor low frequency standing waves are well controlled by positioning ASC Tube Traps™ in the corners of the room. Very serious low frequency accentuation usually requires a custom-designed bass trap system.

Low frequency standing waves can be particularly troublesome in rooms constructed of concrete or brick. These materials trap the bass in the room unless it is allowed to

leak out of the room through windows and doors.

In general, placement of the speaker in a corner will excite the maximal number of standing waves in a room and is to be avoided for most direct radiator, full-range loudspeaker systems. Some benefit is achieved by placing the stereo pair of loudspeakers slightly asymmetrically in the listening room. This is so the standing waves caused by the distance between one speaker and its adjacent walls and floors are not the same as the standing wave frequencies excited by the dimensions in the other channel.

Comb Filter Effect

The “comb filter” effect is a special type of standing wave noticeable primarily at higher frequencies and shorter wavelengths.

Acoustical comb filtering occurs when sound from a single source, such as a loudspeaker, is directed toward a microphone or listener from a distance. The first sound to reach the microphone is the direct sound, followed by a delayed, reflected sound. At certain frequencies, cancellation occurs because the reflected sound lags in phase relative to the direct sound. This cancellation is most apparent where the two frequencies are 180 degrees out of phase. Further, there is augmentation at other frequencies where the direct and the reflected sounds arrive in phase. Because it is a function of wavelength, the comb filter effect will notch out portions of the audio spectrum at linearly spaced intervals. Subjectively, comb filter effect evidences itself as follows:

- Added roughness to the sound
- Reduction of harmonic richness
- Smearing of lateral soundstage image focus and placement

Comb filter effects are often caused by side wall reflections. They are best controlled by very careful speaker placement and by the judicious placement of Illbruck Sonex® or

air duct panels applied to that part of the wall where the reflection occurs.

Section 2.3 – Resonances

Resonance in listening rooms is generally caused by two sources:

- Structures within the listening room.
- The volume of air itself within the listening room.

Structural Resonance

Structural resonances are familiar to most people as buzzes and rattles, but this type of resonance usually only occurs at extremely high volume levels and is usually masked by the music. In many wood frame rooms the most common type of structural resonance problem is “booming” of walls and floors. You can test for these very easily by tapping the wall with the palm of your hand or stomping on the floor. Most rooms exhibit mid-bass “boom” when struck. The loudspeaker playing in the room also excites these resonances. To give you an idea of what the perfect wall would sound like, imagine rapping your hand against the side of a mountain. Structural wall resonances generally occur in the low to mid-bass frequencies and add a false fullness to the tonal balance. They, too, are more prominent at louder levels, but their contribution to the sound of the speaker is more progressive. Rattling windows, picture frames, lamp shades, etc., can generally be silenced with small pieces of caulk or with blocks of felt. However, short of actually adding additional layers of sheet rock to flimsy walls, there is little that can be done to eliminate wall resonances.

Volume Resonance

The physical dimensions and volume of air in a room will also support standing wave modes and resonances at frequencies determined by the size of that room. Larger rooms will resonate at a lower frequency and have more complex (better) modal distri-

butions than will smaller rooms. Volume resonances, wall panel resonances, and low frequency standing waves combine to form a low frequency coloration in the sound. At its worst, it is a grossly exaggerated fullness, which tends to obscure detail and distort the natural tonal balance of the speaker system.

Occasionally, however, there is just enough resonance to give a little added warmth to the sound – an addition some listeners prefer. Careful placement of loudspeakers in the room can dramatically reduce the speakers' destructive interaction with low frequency modes. ASC Tube Traps™ are effective in reducing some of this low frequency room coloration. Custom designed bass traps, such as perforated Helmholtz resonators, provide the greatest degree of low frequency control.

Section 2.4 – Your Room

Room Shapes

Standing waves are pressure waves propagated by the interaction of sound and opposing parallel walls. This interaction creates patterns of low and high acoustical pressure zones that accentuate and attenuate particular frequencies. Those frequencies are dependent on room size and dimension.

There are three basic shapes for most rooms: square, rectangular, and L-shaped (see Figure 4).

A perfectly square room is the most difficult room in which to set up speakers. By virtue of its shape, a square room is the perfect medium for building and sustaining standing waves. These rooms heavily influence the music played by loudspeakers, greatly diminishing the listening experience.

Long, narrow, rectangular rooms also pose their own special acoustical problems for speaker setup. They have the ability to create several standing wave nodes, which will have different standing wave frequency exaggerations depending on where you are

sitting. Additionally, these long rooms are often quite lean in the bass near the center of the room. Rectangular rooms are still preferred to square rooms because, by having two sets of dissimilar length walls, standing waves are not as strongly reinforced and will dissipate more quickly than in a square room. In these rooms, the preferred speaker position for spatial placement and midrange resolution would be on the longer walls. Bass response would be reinforced by speaker placement on the short walls.

In many cases, L-shaped rooms (See Figure 4) offer the best environment for speaker setup. Ideally, speakers should be set up along the primary (longest) leg of the room. They should fire from the end of the leg (short wall) toward the L, or they should be along the longest wall. In this way, both speakers are firing the same distance to the back wall.

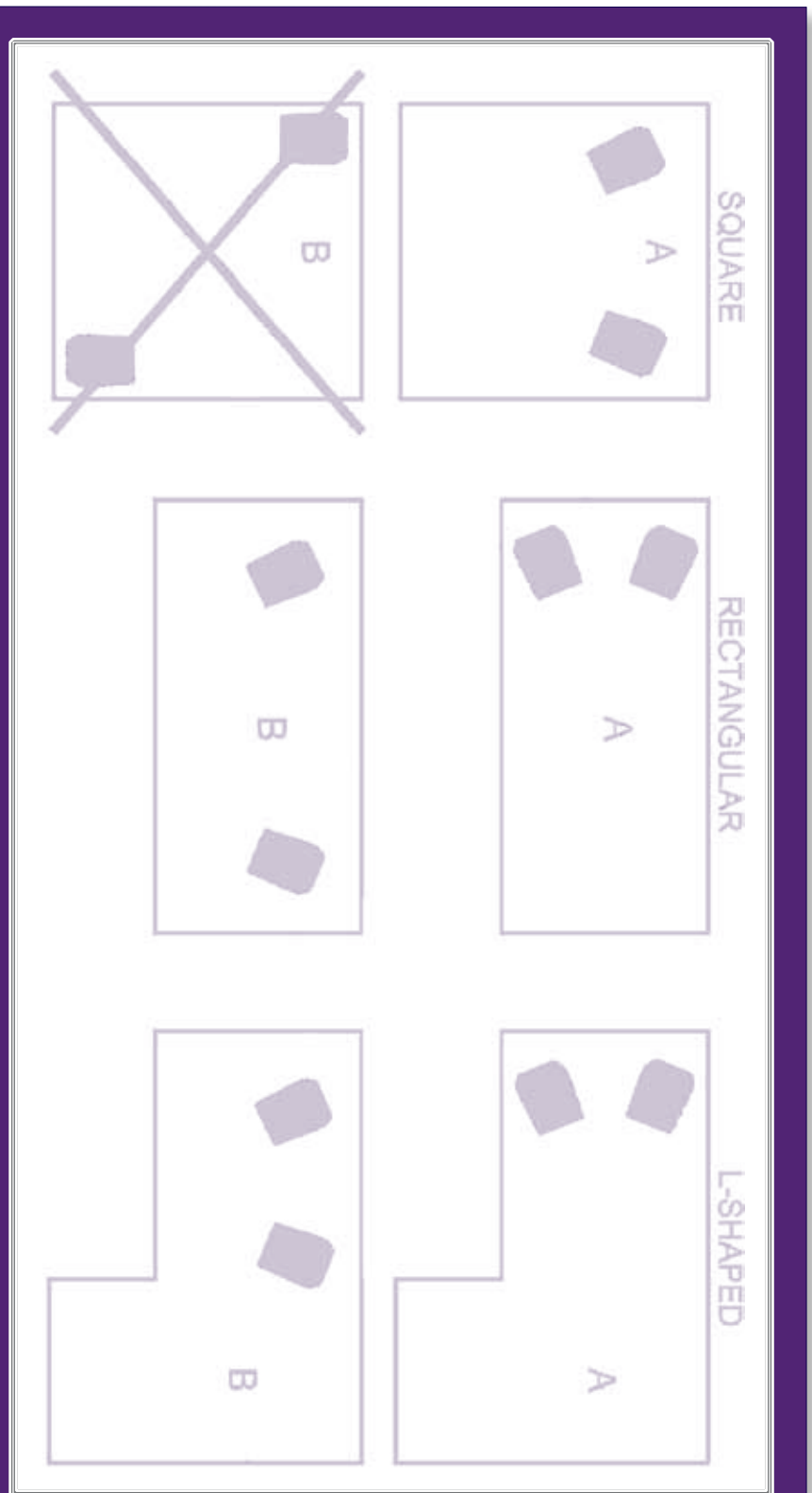

FIGURE 4 – POSSIBLE LOUDSPEAKER PLACEMENT WITHIN VARIOUS ROOM SHAPES

The asymmetry of the walls in L-shaped rooms resists the buildup of standing waves (see Figure 4).

Alexandria X-2 Series 2 in a Dedicated Home Theater

Home theaters can be organized many different ways. Some use rows of couches. Others use rows of multiple chairs.

In addition to watching movies, most users want to listen to two-channel music at the highest quality possible. It is desirable, therefore, to choose a single optimum seating position in a home theater and build the rest of the seating positions around this position.

If your optimum position is located on a couch, you should center the loudspeakers on the middle position of the couch.

If the seating area consists of multiple rows of chairs, the second row should be optimized for the best sound quality. Odd numbers of chairs arranged in rows work best as this will allow a single chair to be positioned in the center. This approach will also provide the best overall sound for the greatest number of seats.

Speaker Placement Versus Listening Position

The location of your listening position is as important as the careful setup of your Alexandria speakers. The listening position should ideally be no more than 1.1 to 1.25 times the distance between the tweeters on each speaker. Therefore, in a long, rectangular room of 12' x 18', if the speaker tweeters are going to be 9' apart, you should be sitting 9'11" to 11'3" from the speaker. This would be more than halfway down the long axis of the room.

Many people place the speakers on one end and sit at the other end of the room. This approach will not yield the finest sound. Carefully consider your listening position. Our experience has shown that any listening position that places your head closer than 14" from a room boundary will diminish the sonic results of your listening.

Decide where you want your favorite listening position to be. Please remember that your Alexandria X-2 Series 2 will fill almost any room with the most beautiful sound available. Because the propagation delay is adjustable on the Alexandrias, if you take care in placing your new speakers, you will optimize Alexandria's performance in your room.

Speaker Orientation

Speaker placement and orientation are two of the most important considerations in obtaining superior sound. The first thing you need to do is eliminate the sidewalls as a sonic influence in your system. Speakers placed too close to the sidewalls will suffer from a strong primary reflection. This can cause out-of-phase cancellations, or comb filtering, which will cancel some frequencies and change the tonal balance of the music. The Wilson Audio Setup Procedure (Section 2.1) is the best method with which to position your loudspeakers. Start with the speakers about 18" from each wall and, if you need to move them relative to the side wall, move them away from the wall, not closer.

A very important aspect of speaker placement is how far from the back wall to place the speakers. The closer a loudspeaker is to the back wall, the more pronounced the low bass energy and centering of the image will be. However, this comes at a definite reduction in stage size and bloom as well as a deterioration of upper bass quality. You must find the proper balance of these two factors, but remember, if you are partial to bass response or air and bloom, do not overcompensate your adjustments to maximize these effects. Overcompensated systems are sometimes pleasing in the short-term, but long-term satisfaction is always achieved through proper balance.

The Series 2 Alexandria is designed for maximum phase coherence and pulse replication accuracy when each speaker is aimed directly at the listener or microphone. Thus, your Alexandria should be "toed in." In other words, the listener, when seated in the listening position looking forward with his/her head in a rested position, should just

barely see the surface of the inner side of each Alexandria. Toeing in the speakers provides meaningful improvements in resolution of low-level detail in the midrange as well as appreciable improvements in soundstaging performance.

Summary

In summary, for optimal tonal balance accuracy, resolution of low level detail, and soundstaging performance, the Alexandria X-2 Series 2 should be positioned as outlined in this section. Ideally, the speakers should not be positioned too far from the listener if maximum resolution of low-level detail is required. If possible, the speakers should be positioned out into the room, slightly asymmetrically vis-a-vis the side and rear walls. The speakers should be “toed in” toward the listener, preferably so that the listener, at his seated position, can barely see the surface of the inner side of the Alexandria as he/she faces the speaker. It is recommended that a distance of two to three feet, and possibly more, be maintained between the Alexandria and the rear walls and that a distance of at least two feet be maintained between the front panel of the Alexandria and reflective side walls. Depending on the room, judicious use of sound absorbent materials will reduce the space requirement.

By following the guidelines in this manual, your new Alexandria X-2 Series 2 loudspeakers can provide you with a lifetime of pure music reproduction.

SECTION 3 - UNCRATING THE ALEXANDRIA



Note: You will have many modules to unpack that will need to be separated into right and left channels. Clear out two spaces, one for your left and one for your right channel modules. Place the ODD numbered modules in the LEFT channel section and the EVEN in the RIGHT channel section. Prior to assembly, stage the modules away from the area where the speakers are to be assembled. This will avoid clutter in the work area that can result in damage to your loudspeakers.

Section 3.1 – Uncrating the Alexandria

Initial Check

The Alexandria is shipped in seven wooden crates. Upon receiving these crates, please check their condition. If any of the crates are damaged, please report it to the shipping company immediately for insurance verification.

Tools Required

- Metal shears
- Variable speed, reversible electric drill
- Phillips head drive bit

Uncrating the Woofer Modules

A minimum of two strong adults is required to set up the system. Locate the two largest crates labeled “Woofer Module.” These contain the woofer en-



closures and are the first components of the system to unpack (see Figure 5).

Note: These two woofer enclosures are very heavy and when moving or lifting, care should be taken in order to prevent injury.

Unpacking the Woofer

1. Open the top of each crate and determine the side where the casters are connected to the bottom of the woofer module.
2. Remove the packing material from between the casters and set the crate up so that the casters on the woofer are toward the floor.
3. While one person holds the crate, the other person should roll the woofer enclosure out of the crate. Be very careful not to scratch the module during this process.
4. Finally, move the woofer cabinets over to the “Zone of Neutrality” as determined by the Wilson Audio Setup Procedure. If you have not yet performed this room analysis, please refer to Section 2.1 of this manual. Reminder: Place the odd serial numbered woofer on the LEFT and the even numbered woofer on the RIGHT.
5. Remove the empty woofer crates from the room.

Uncrating the Aspherical Wings

Locate the two crates labeled “Wing Assembly” (see Figure 6). These contain the wings that support the upper modules.

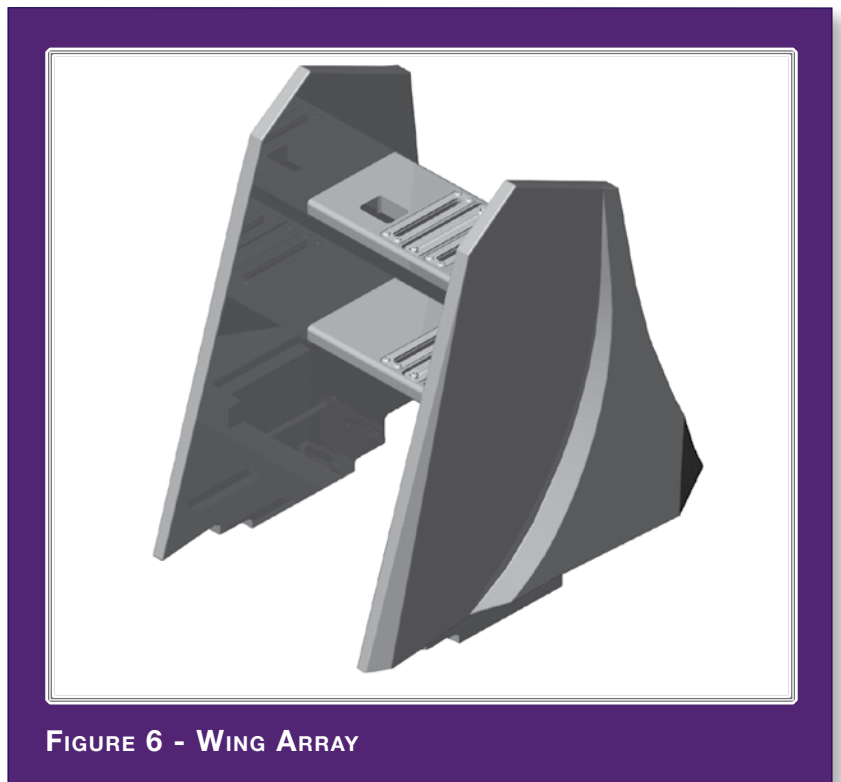

FIGURE 6 - WING ARRAY

1. Cut the bands on the crate.
2. Remove all the screws from the top and sides of the crate.
3. Pull the top of the crate off, and pull the sides of the crate apart.
4. Because the wing array is extremely heavy, use two strong people to carefully lift the wing array out of the crate.
5. Locate the serial plate on the underside of the lower horizontal support. Place the wings on the floor near the woofer modules, matched to the woofer module with the same serial number.
6. Remove the empty shipping crates from the room.

Uncrating the Upper Array Modules

1. Locate the two crates labeled “Upper Modules.” Remove the three upper modules, from each crate (see Figure 7). It is very important to ensure that each of the modules are matched to one another by serial number. The serial tags are located on the un-



UPPER MIDRANGE MODULE (UMRM)

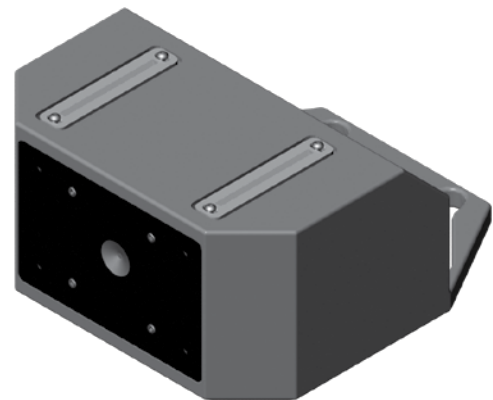

HIGH FREQUENCY MODULE (HFM)

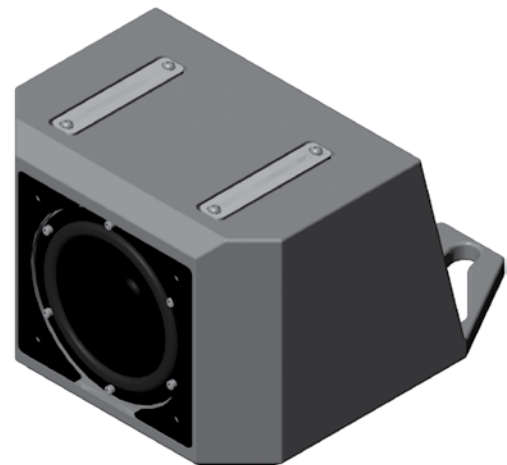

LOWER MIDRANGE MODULE (LMRM)

FIGURE 7 - UNCRATE UPPER MODULES



FIGURE 8 - PROPAGATION DELAY COVER

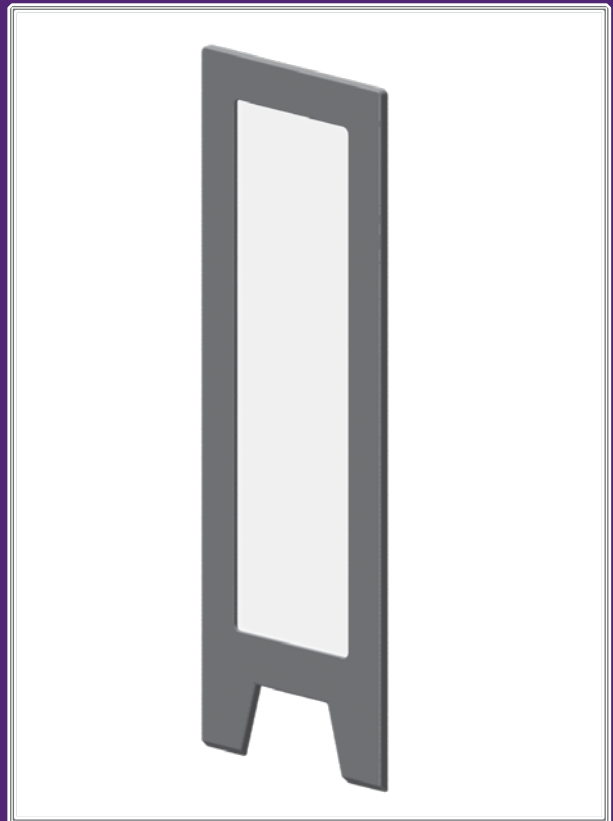

FIGURE 9 - RESISTOR PLATE COVER

derside of each module. Be very careful in unpacking the remaining modules to avoid chipping the finish.

2. Stage these items away from traffic flow.
3. Remove the empty crates from the room.

Uncrating the Crossover Cover

1. Locate the crate labeled "Crossover Covers" (see Figures 8 & 9). This crate contains the propagation delay cover and the resistor plate cover. It also contains tool kits, a jack, and an owner's manual. Remove the covers from the crate. Take care to observe the serial number and place the covers with the corresponding channel's modules.
2. Remove the empty crates from the room.

Crate Contents Checklist

Now that you have everything unpacked, you can inventory your items.

- 1 - Owners manual
- 2 - Woofer modules (left & right channel)
- 2 - Lower midrange modules (left & right channel)
- 2 - High frequency modules (left & right channel)
- 2 - Upper midrange modules (left & right channel)
- 2 - Wing Arrays (left & right channel)
- 2 - Propagation Delay Alignment Plates (left & right channels)
- 8 - 3/8"-16 x 1.5 set screws
- 8 - Spikes, with nuts
- 8 - Woofer Mechanical Diode
- 1 - Caster wrench
- 1 - Jack
- 1 - 9/16" Combo wrench
- 1 - 3/16" Long-arm Allen wrench
- 1 - 5/32" Allen wrench
- 1 - 1/2" Binding post wrench
- 1 - 9/64" Allen wrench
- 4 - Expansion spike sub-assemblies
- 18 - "A" spikes
- 6 - "B" spikes
- 6 - "C" spikes
- 6 - "D" spikes
- 6 - "E" spikes
- 12 - #1 Tether bolts
- 12 - #2 Tether bolts

12 - Tether bolt threaded covers

2 - Polishing cloths

8 - Large Brass spike pads

1 - Bottoming tap - 3/8"-16

1 - Tap Handle

12 - 1/4" x .468" Washer

12 - 1/4" - 20 x 1 1/4" Socket head screws

16 - 10 - 32 x 1" Socket head screws

16 - 10 x .438" Washer

Complete set of resistors:

4 sets of 2 (soldered in series) - .75 ohm tweeter and/or midrange level resistors

2 - 34.6 ohm midrange phase resistor

2 - 27.3 ohm woofer barrel resistor, (for solid state amplifiers)

4 - 23.4 ohm woofer barrel resistor, (for tube amplifiers)

Note: After set up of the system, keep the shipping crates in case of future shipping needs.

SECTION 4 - ASSEMBLING YOUR ALEXANDRIAS



Section 4.1 – Initial Assembly

In order to realize the capabilities of the Alexandria, we strongly recommend that you have it installed by a trained Wilson Audio installer. Your dealer will have a person trained in the art of the Alexandria installation. If you choose to do this installation yourself, here are some guidelines to assist you. These guidelines come from many years of experience and should be followed closely.

First, place the woofer modules in the Zone of Neutrality as determined by the procedure outlined in Section 2.1. Final setup and tuning will follow the assembly of your Alexandrias.

Remove the protective film covering the painted surfaces on the modules, wing assemblies, and crossover covers. Start at the edge and slowly peel it off.

The propagation delay plate is installed for shipping. Remove the plate and set aside (see Figure 10).

Each wing array has a serial plate on the bottom surface of the lower alignment plate. There are corresponding numbers on the woofer module. Make



FIGURE 10 – REMOVE PROPAGATION DELAY PLATE

sure to match each wing to its corresponding woofer module.

Carefully lower the wing onto the woofer module. Locate six 1/4 inch diameter – 1 1/2" hex head screws. Attach wing assembly to woofer (see Figure 11).

Re-attach Propagation Delay Plate

- Locate eight 10 - 32 x 1" bolts with metal washers.
- Locate the propagation delay alignment plate.

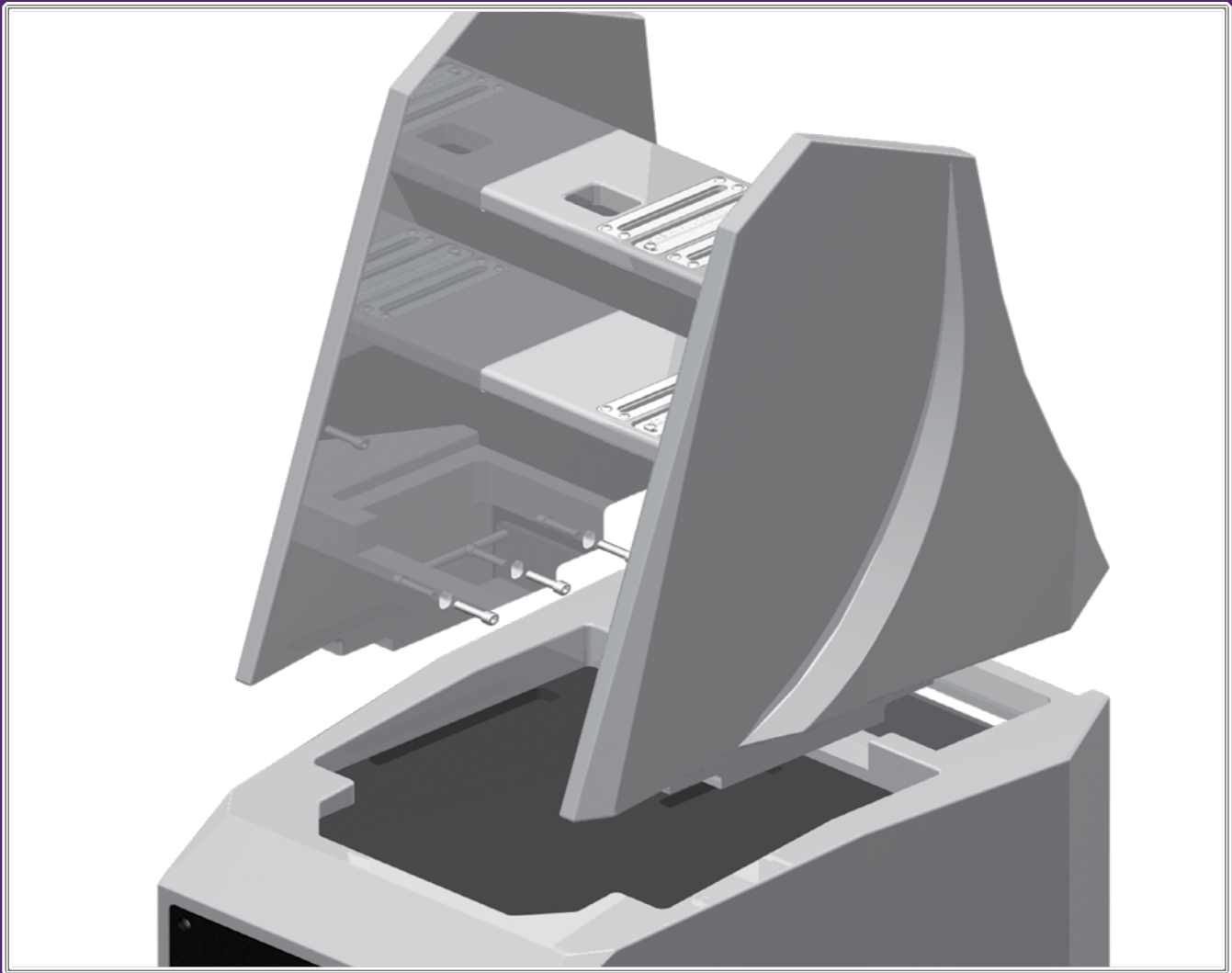

FIGURE 11 – CAREFULLY INSTALL WING ARRAY AND BOLT IT TO THE WOOFER MODULE.

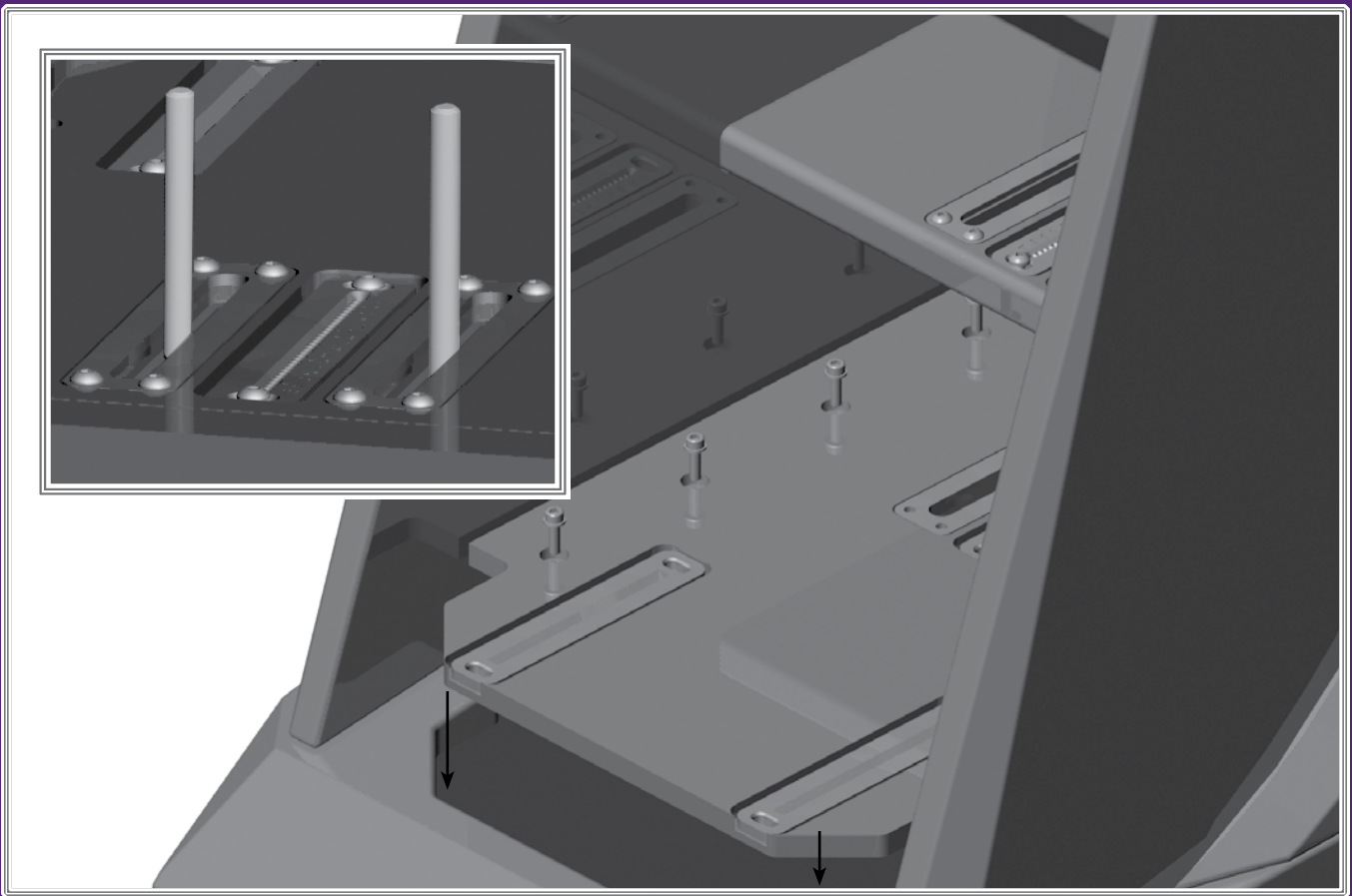

FIGURE 12 – WHEN RE-INSTALLING THE PROPAGATION DELAY PLATE, INSERT THE TETHER BOLTS IN THE REAR SLOTS ON EITHER SIDE OF THE NUMBERED PLATE.

- Select the proper tether bolt by referring to the lower midrange module tether bolt length table found in Section 8. See Section 4.2 below for the process to determine the proper tether bolt.
- Locate the two appropriate length lower midrange module tether bolts.
- Insert tether bolts through the bottom of the plate (see Figure 12) so that the threaded portion of the bolt protrudes through the top of the plate.
- Attach the plate to the top of the woofer module (see Figure 12). Ensure that the tether bolts stay in place.
- Secure the plate with the eight 10 - 32 x 1" bolts, placing the metal wash-

ers beneath each bolt.

- Repeat the above process for the other channel.

Section 4.2 – Geometric Time Domain Alignment

Materials Required:

- Tape measure
- Known listening position (see Section 2)
- Alexandria Propagation Delay Alignment Tables from Section 8

Propagation Delay Alignment

Propagation delay alignment accuracy of the Alexandria has been established and

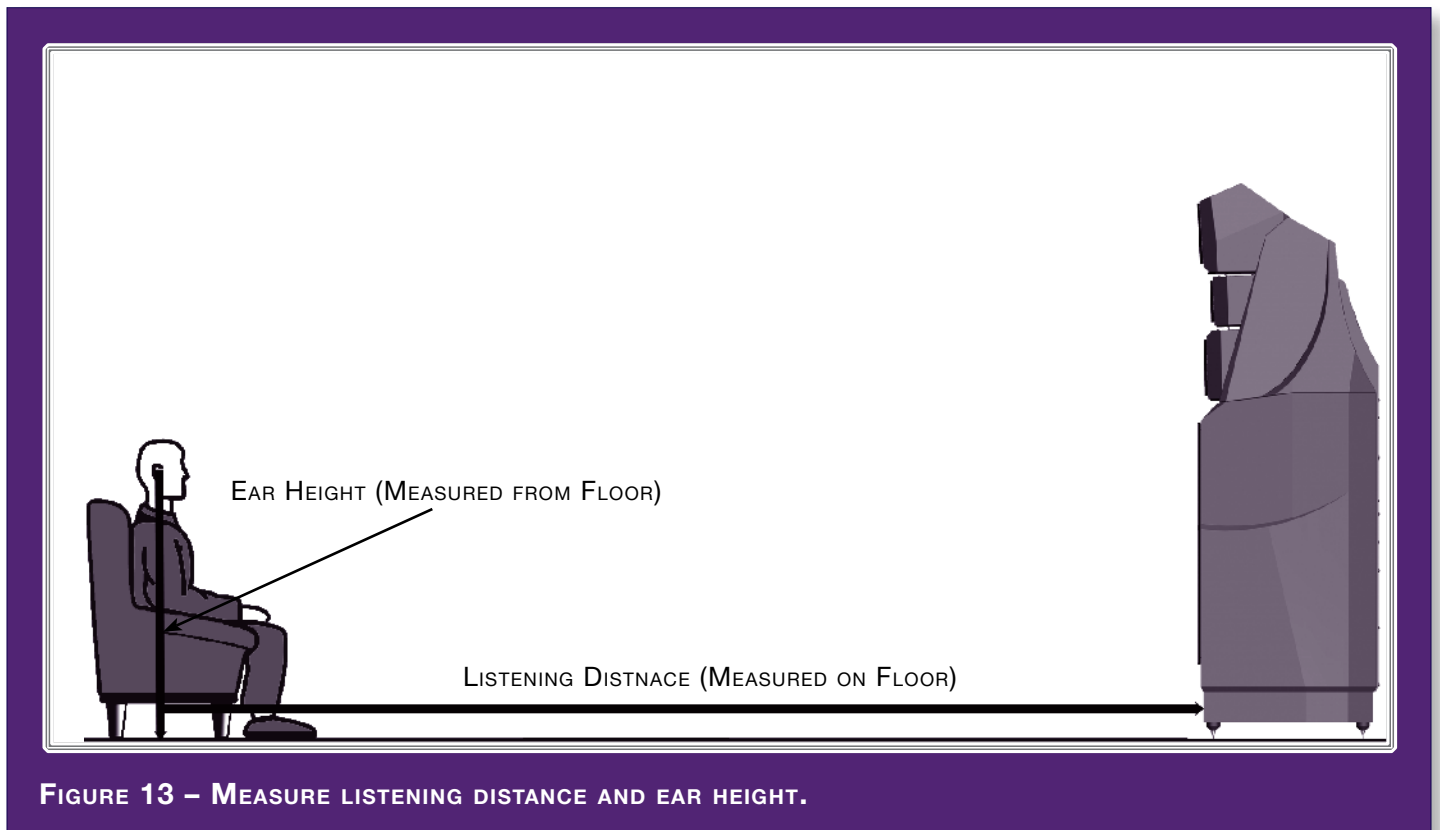

verified by Wilson Audio. The graphs and charts used in this section are a result of this testing.

Room Setup

As indicated in Figure 13, the Alexandria system allows for different listening distances (away from the speakers) and listening ear heights (measured distances from the floor to your ear). For each distance/ear height combination there is a unique alignment geometry.

To make correct in-home set up of the Alexandria possible without test equipment, Wilson Audio has measured the correct geometric time domain alignment for different distance/ear height combinations. This information is provided in the Propagation Delay Tables in Section 8. By measuring the ear height and the distance from the speaker to the listening position, you will be able to align the system for your listening position.

Alignment Procedure

Each upper module's **rear spike** rests in a specific **numbered indent** that determines its individual propagation delay position within the modular array. Each alignment plate contains numbered indents, numbered 1 to 33 (see Figure 14). The alignment tables contain the information for positioning each module in the array, determined by the indent in which the rear spike rests. The table also contains information on the appropriate length spike to be used in the rear of the module. Determine the alignment of each upper module as follows:

Identification of Alignment Spikes and Tether Bolts

1. Repeat each step of this procedure on the left and right channels simultaneously.
2. Remove the Propagation Delay Tables from Section 8 in this booklet and place them close by for easy reference.

3. Make sure that you are in your intended listening position.
4. While sitting, have someone measure your ear height from the floor directly below your ear. You should be relaxed in your chair, as you would be when listening to music (see Figure 13).
5. Now measure the distance (on the floor) from the point on the floor below your ear to the base of the loudspeaker, as shown in Figure 13.
6. Refer to the Propagation Delay Tables (see Section 8) and locate the corresponding ear height for each module. There are three charts per module; the first is a table determining the rear spike length, the second is a nomograph (accompanied by a table) determining each module's rear spike indent location, and the third table specifies the appropriate Tether Bolt length.
7. Make a mark on the "Rear Spike Length" tables indicating the proper rear spike for each module.

Note: The shortest spikes (labeled A) are always used at the front of all upper modules.

8. Make a mark on the "Rear Spike Detent Location" table indicating the proper rear spike location for each module. Set this information aside as you will refer to it in the next section.



FIGURE 14 - ALIGNMENT PLATE WITH SPIKE DETENTS

9. After determining each module's correct spike length, refer to the Tether Bolt Table to determine the proper bolts to be used for each of the upper two modules. Set these aside as you will need them later.

Section 4.3 – Mounting Upper Array Modules

Materials Required

- Correct spikes for the modules. Refer to the Alexandria Propagation Delay Tables and the procedure in the previous section to determine the correct Aspherical Propagation Delay spikes necessary for each head.
- The correct four remaining tether bolts for the upper two modules as determined by the table in Section 8.
- Four expansion spike sub-assemblies.

Mounting Procedure

Note: The module's center of gravity will be somewhat forward and unbalanced until the tether bolts are secured. Have an assistant stabilize them while you install rear spikes



FIGURE 15 - INSTALL THE ALIGNMENT SPIKES INTO THE UPPER MODULES.

and heads.

The front-to-back **location** of each module, along with the use of the proper length of rear spike of the upper modules, achieves the correct propagation delay and axial response vis a vis the listener.

Install the front pair of short (A length) spikes into the bottom of each module (see Figure 15).

Install the Lower Midrange Module (LMRM)

The lower midrange module (LMRM) is installed first. Install the module as follows:

- With the front spikes pointing down, carefully lower the LMRM between the alignment wings and set it on top of the woofer enclosure (see Figure 16). Ensure that the tether bolts are protruding through the slots provided in the module handle. There are alignment tracks that accommodate the spikes. Refer to the Propagation Delay Table to determine the numbered indent in which to rest the rear spike.
- It is now safe to install the rear spike by lifting the module by its rear handle and carefully screwing in the spike.
- The rear spike track is indexed numerically. Refer to your marks on the Propagation Delay Table in Section 8.0 to determine the numbered detent in which to rest the rear spike.

Install the High Frequency Module (HFM) as follows:

- With the front pair of short spikes pointing down, carefully lower the HFM between the alignment wings and set the front two spikes on top of the LMRM enclosure. Align the spikes into the alignment tracks. Install the rear spike by lifting the rear of the HFM and carefully screwing it in.
- Refer to the Propagation Delay Table in Section 8 to determine the proper location of the rear spike, noting that the position will be different from the LMRM.

Install the Upper Midrange Module (UMRM) as follows:

- With the front pair of short spikes pointing down, carefully lower the UMRM between the alignment wings. Set the front two spikes on top of the HFM enclosure, into the tracks. Install the rear spike by lifting the rear of the UMRM and carefully screwing it in.
- Refer to the Propagation Delay Table in Section 8 to determine the proper location of the rear spike, noting that the position will be different from the other two modules.

Section 4.4 – Connecting the Upper Modules' Signal Cable

The Alexandria uses binding posts that were designed in-house and are manufactured exclusively for Wilson Audio. The design goal was to create a connector with superior overall sound quality, consistency, and longevity.

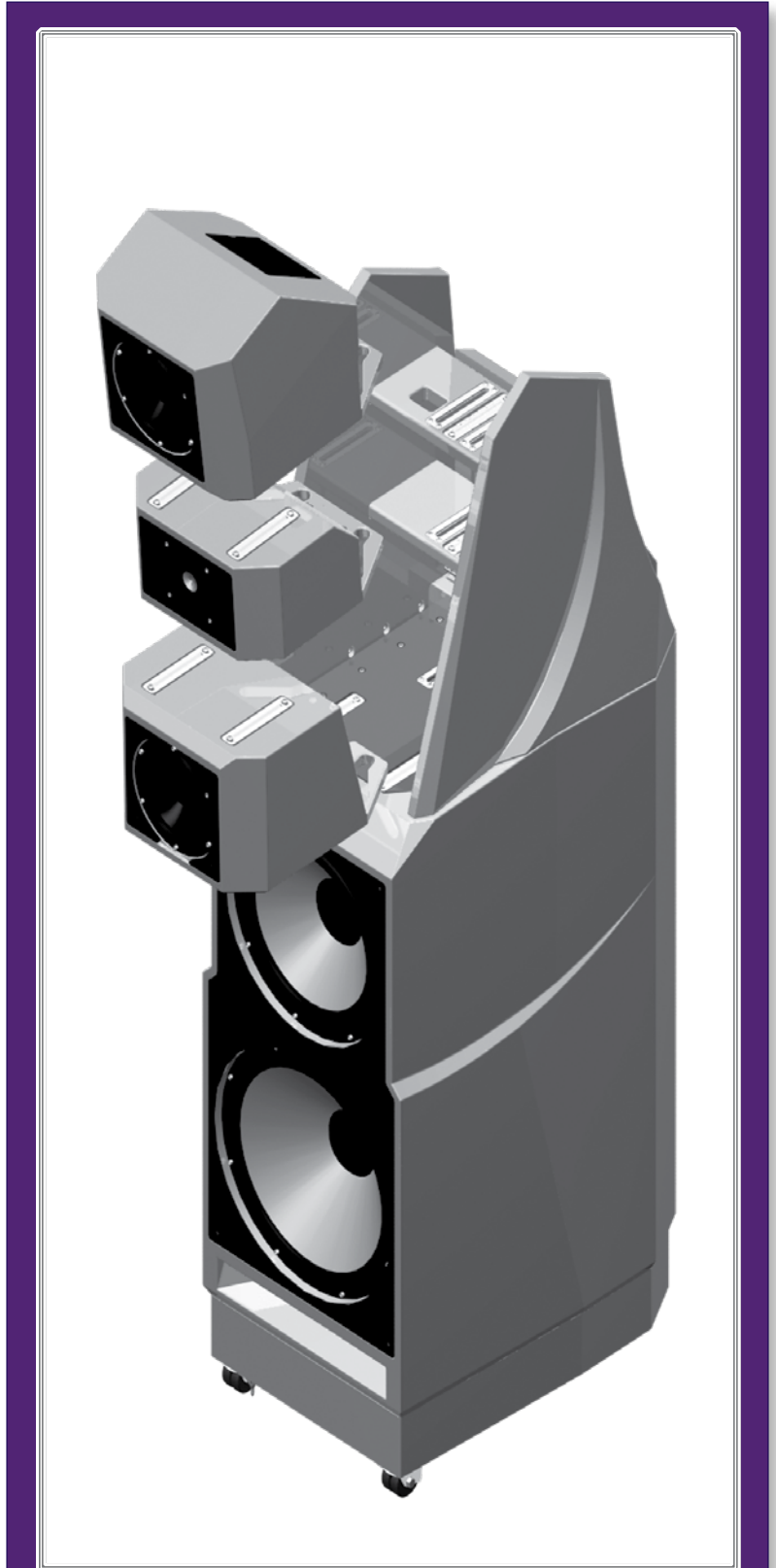

FIGURE 16 - INSTALL THE UPPER MODULES INTO THE WING ARRAY.

A note about these connectors: You risk breaking the binding post if they are over-tightened. Use the supplied binding post wrench and tighten until just snug.

The upper range signal cables are labeled so that they can be easily attached to their appropriate module. This is accomplished as follows:

- Locate the cable marked "Lower Mid." Dress this cable through the handle opening and connect this cable to the lower midrange module (LMRM) loudspeaker binding post (see Figure 17).
- Locate the cable marked "Front Tweeter." Dress this cable through the handle opening and connect it to the high frequency module (HFM) loud-

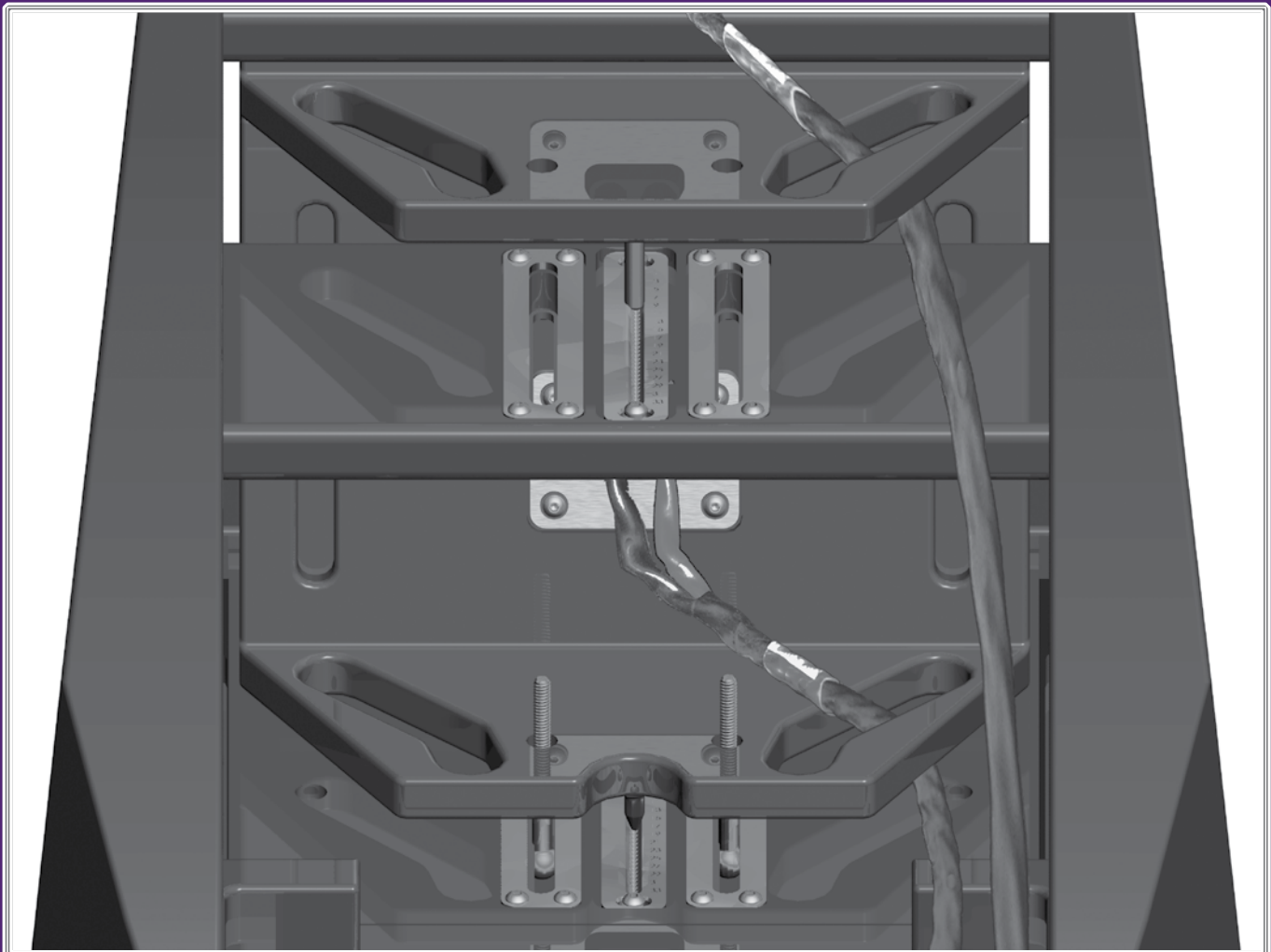

FIGURE 17 - CABLE DRESSING.

speaker binding post (see Figure 17).

- Locate the cable marked “Upper Midrange.” Locate the binding post on the rear of the upper midrange module (UMRM) labeled “Mid Frequency.” Carefully thread the speaker cable up through the hole located in the wing support and through a corresponding hole located on the module support blade just below the speaker terminal (see Figure 18).
- Locate the cable marked “Rear Tweeter.” Locate the binding post on the rear of the upper midrange module labeled “Rear Tweeter.” Carefully thread the speaker cable up through the hole located in the wing support

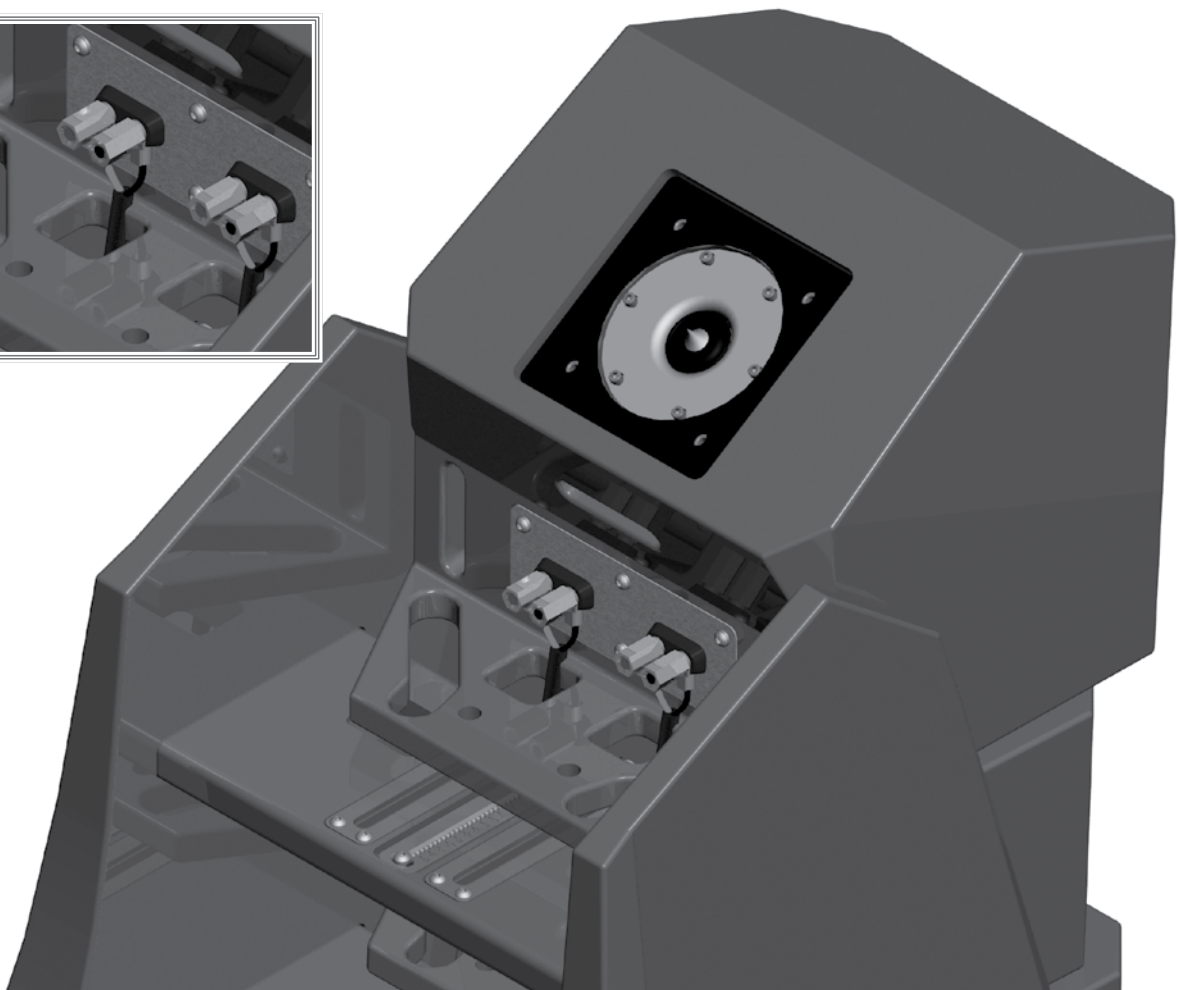
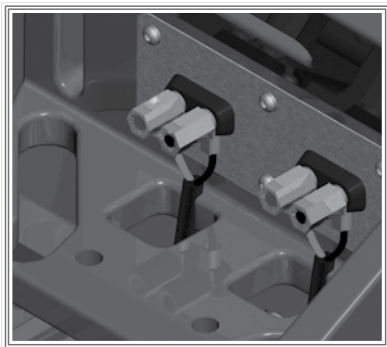

FIGURE 18 - CONNECT CABLES TO THE UPPER MODULES.



FIGURE 19 - INSTALL THE TETHER BOLTS. CUTAWAY OF X-2 SHOWING BOLT ASSEMBLY.

and through a corresponding hole located on the module support blade just below the speaker terminal (see Figure 18).

Section 4.5 – Locking Down The Upper Modules

Materials Required

Refer to “Identification of Alignment Spikes and Tether Bolts” in Section 4.1 under “Geometric Time Domain Alignment” to ensure that you have the proper length tether bolts for each loudspeaker’s upper two modules.

- 2 - Tether bolt cap nuts for each loudspeaker's lower midrange module (LMRM).
- 2 - Tether bolts for each loudspeaker's high frequency modules (HFM).
- 2 - Tether bolt cap nuts for each loudspeaker's high frequency modules (HFM).
- 2 - Tether bolts for each loudspeaker's upper midrange module (UMRM).
- 2 - Tether bolt cap nuts for each loudspeaker's upper midrange module (UMRM).

Installing The Tether Bolts

- The tether bolts for the lower midrange module have already been installed beneath the alignment plate (see Section 4.1). Place the tether cap nuts and rubber washers on the bolts, alternatively tightening them in small increments so that LMRM is tensioned symmetrically and snugly against the propagation delay spike (see Figure 19).

Note: Do not use any tools to tighten the tether cap nuts. Hand tighten only. Overtightening of the bolts can damage the module.

- Insert the high frequency module (HFM) tether bolt through the bottom of the center wing plate, up through the the corresponding tether bolt slot on the module handle. While holding the bolt in place, thread the tether cap nut onto the bolt and loosely tighten it. Install the second HFM tether bolt using the same process. After the two bolts are secured in place, check to ensure that the alignment spike is still placed properly in its numbered dent. Symetrically hand tighten the tether cap nuts.
- Using the same process, insert and symetrically tighten the tether cap nuts for the upper midrange module.

Section 4.6 – Spike Installation

SPIKE ASSEMBLY

- Remove the mechanical diodes and move the nut to about two threads from the point. This will allow for greater movement when leveling the loudspeaker system.

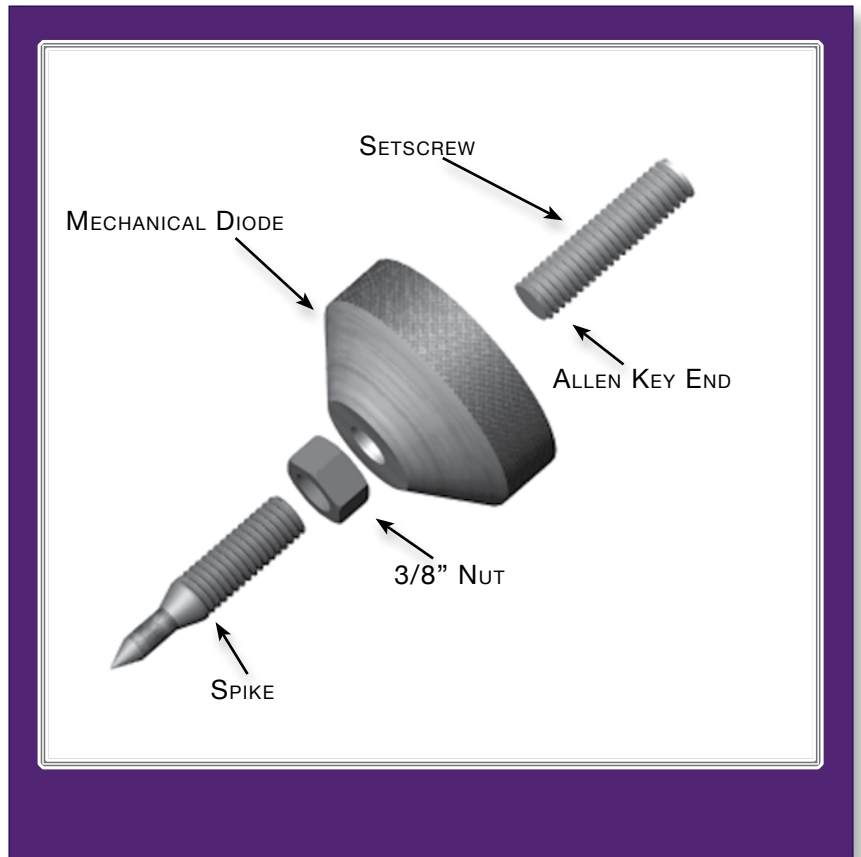

- Screw the spikes into the diode until the nut is against the diode. Be careful that the nut does not turn while inserting and threading spikes into the diode.

Note: Do not tighten these assembled spikes. You will need to unscrew them when you level the Alexandrias.

- Place the set screw into the other end of the diode **with the Allen head toward the spike**. This will ensure that if for any reason you have to remove your Alexandria spikes, you will be able to withdraw the set screw safely using the supplied Allen wrench. Screw the set screw into the diode until it meets the spike (see Figure 20).
- Place the assemblies out of the traffic pattern until they are needed during the installation.

Section 4.7 – Using the Lift to Install Spikes

Materials Required

Note: This is a two person job. Do not attempt this by yourself. The Alexandrias weigh over 700 LBS and may seriously injure someone if tipped over.

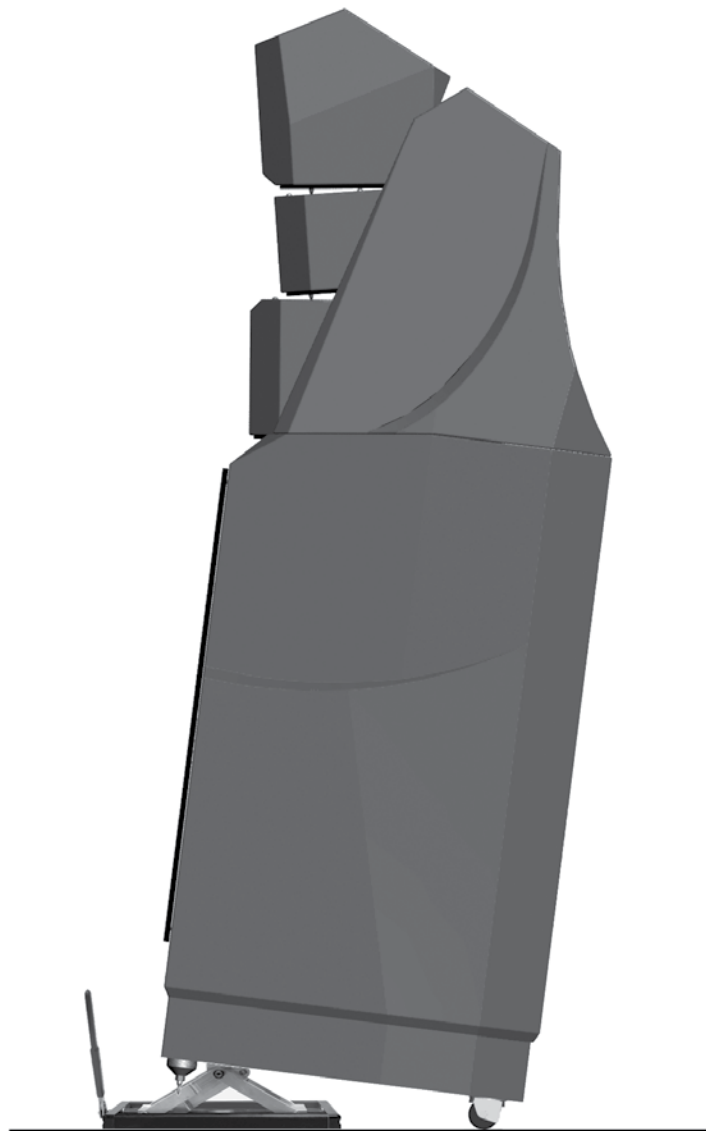

FIGURE 21 - INSTALLING THE SPIKES USING THE WILSON AUDIO JACK

- 8 sets of assembled spikes
- The Wilson Audio Jack
- The jack socket wrench
- Swivel caster wrench

Installation Procedure

- Lock the rear casters to prevent the Alexandria from moving.
- Slide the Wilson Audio Jack under the front of the Alexandria, centered between the casters, so that the jack's lift bolt is exposed. Place the lift plate so it is positioned about an inch behind the front facade of the Alexandria woofer enclosure (see Figure 21).

Note: An assistant should stand to the rear of the Alexandria to steady it.

- Attach the wrench to the lift bolt and begin to slowly raise the front of the Alexandria by turning the bolt clockwise (see Figure 21).
- After the front of the Alexandria is high enough (you will need approximately one and half inches of clearance beneath the caster), use the swivel caster wrench to loosen the casters. Remove the casters.
- Insert and screw-in the finished spike assembly. **Hand tighten only!**

Note: Be very careful NOT TO CROSS THREAD the spikes. The base of the Alexandrias is made of "X" material and is prone to cross threading.

Note: The spike will go into a different hole than the caster.

- With one person stabilizing the Alexandria, lower the Alexandria by turning the jack counterclockwise. Note that the Alexandria will now sit lower in the front as the spike assembly is shorter than the caster. Use caution.

Note: It is very important, at this point, that an able assistant stabilize the front of the Alexandria until the rear spikes are attached and the unit is lowered.

- Repeat the previous process of the caster removal/spike insertion on the opposite side of the enclosure. Then continue the process on the other channel (see Figure 21).

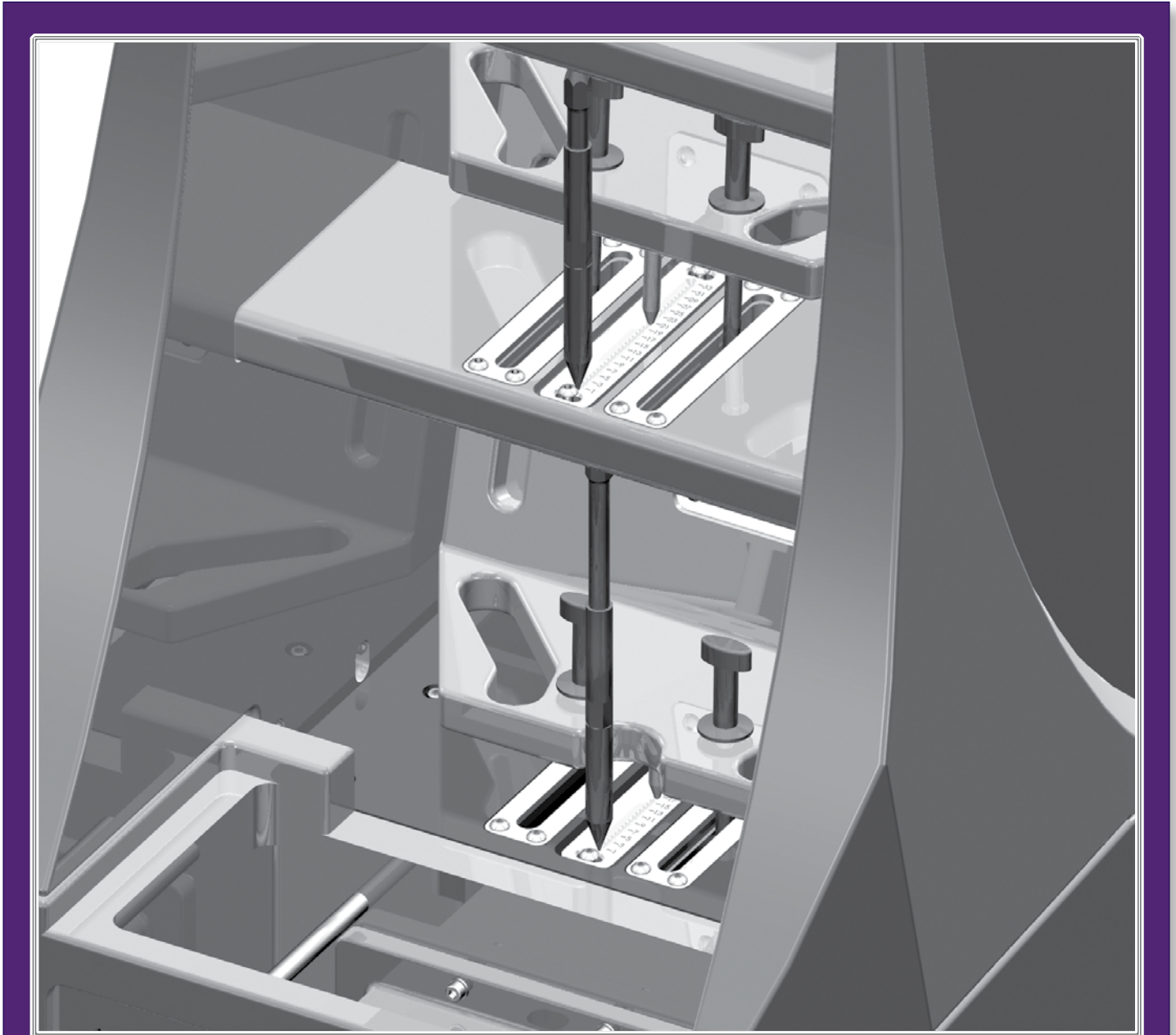

FIGURE 22 - INSTALL THE EXTENSIONS SPIKES.

Leveling the Alexandria

- It is not necessary to use the jack to level the Alexandria.
- Place a level on the left to right oriented axis. If it is level, move to the next step.
- If the bubble shows that the speaker is leaning toward the center of the room, you will have to lengthen one of the inside spikes down toward the floor. If the bubble is leaning toward the outside of the room, you will have to lengthen one of the outside spikes down toward the floor.
- You may rotate the spike tips in place by using a vice-grip or toothed pliers.
- To find out which spike to lower, grasp the Alexandria channel and rock it back and forth. This will identify the spike that is out of level from the other three.
- Place a level on the front to back oriented axis. If it is level, then your Alexandrias are level. If the bubble shows that the speaker is leaning toward the front of the room, you will have to lengthen the front spikes down toward the floor. If the bubble shows that the speaker is leaning toward the back of the room (behind the loudspeakers), you will have to lengthen the rear spikes down toward the floor.

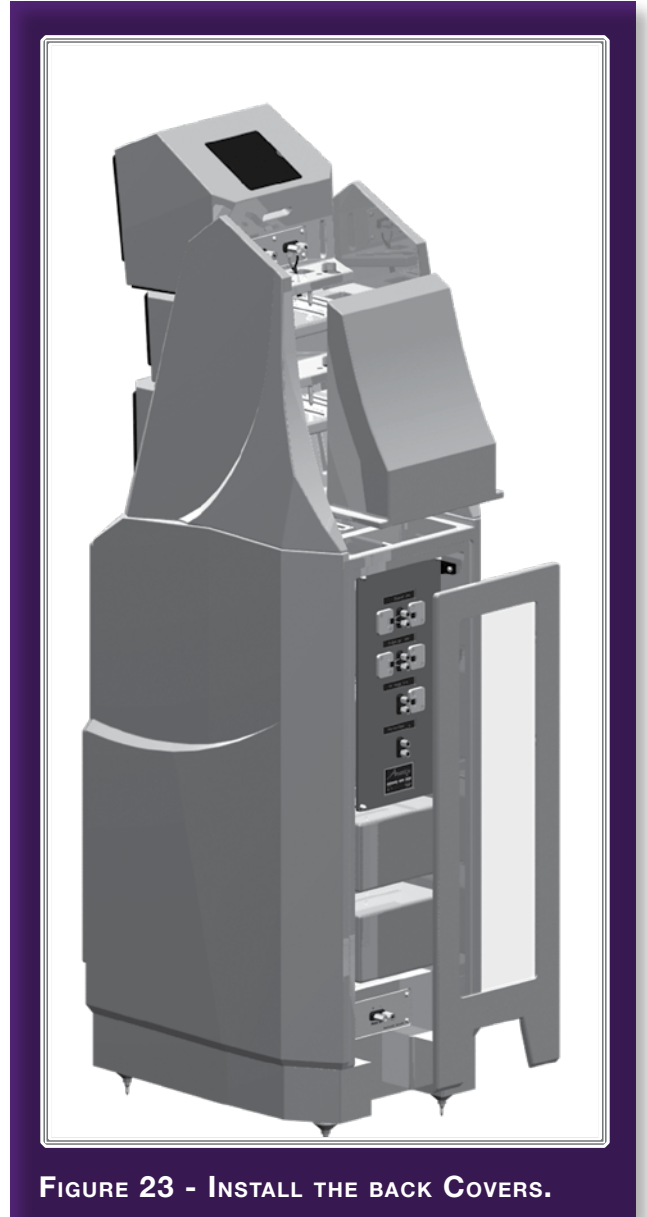

FIGURE 23 - INSTALL THE BACK COVERS.

Section 4.8 – Extension Spikes

Place one end of the expansion spike sub-assemblies into the last hole of the spike track. Expand the sub-assembly until the upper end comes into contact with the dimple in the middle of the brass spike pad found on the underside of the wing braces. Use box end wrenches (included) to snug the expansion spikes securely (see Figure 22).

Section 4.9 – Installing the Back Covers

Attach the cover over the resistor plate. The cover attaches using the same stainless steel pin system as the grills (see Figure 23).

Note: The rear resistor cover features a glass insert. Take care when installing or storing the cover to avoid breaking the glass.

Attach the top cover over the propagation delay hardware.

Section 4.10 – Resistors

By removing the back cover of your Alexandrias, you may gain access to the resistor plate (see Figure 23). These resistors serve several functions.

Note: Only Wilson Audio replacement resistors should be used in your Alexandrias.



Alexandria® Resistor Value Chart X-2		
Front Tweeter	Adjustment Values	Resistor Value
	+1.0 dB	.50 ohms
	0. dB	.75 ohms
	-1.0 dB	1.00 ohms
	-1.5 dB	1.50 ohms
Midrange Level	Adjustment Values	Resistor Value
	+0.5 dB	.50 ohms
	0 dB	0.75 ohms
	-1.0 dB	1.00 ohms
	-2.0 db	1.50 ohms
Midrange Phase	Adjustment Values	Resistor Value
	Do Not Adjust	34.6 ohms
Woofer Damping	Adjustment Values	Resistor Value
	Medium Damping	23.4 ohms
	Light Damping	27.3 ohms

FIGURE 24 - RESISTOR CHART

Changing the value or brand of resistor will have a deleterious affect on the sonic performance of your loudspeakers and may void your Wilson Audio Warranty.

Midrange and Front Tweeter Resistors

The Midrange Level and Front Tweeter Level resistors provide precise level matching for the midrange and tweeter drivers correspondingly. The resistors also act as ultra high quality fuses which open before a driver can be damaged by excess power. See Section 6.0 for details in replacing these resistors in the event one of these two resistors is damaged.

Additionally, these two resistors can be used to tailor the output of the corresponding driver to overcome tonal balance issues that result from room acoustics. Refer to Figures 23 through 25 for information important to this adjustment.

Midrange Phase Resistors

The Midrange Phase resistor is a propagation delay tuning device and **should never be changed or altered by the user.**

Woofer Damping Resistor

The Woofer Damping resistor affects the way the Alexandria's woofers couple to the amplifier. Generally, for direct coupled, solid state amplifiers, the Light Damping resistor (27.3 ohms) should be used. With tube amplifiers, the Medium Damping resistor (23.4 ohms) should be used (see Figures 23 through 25).

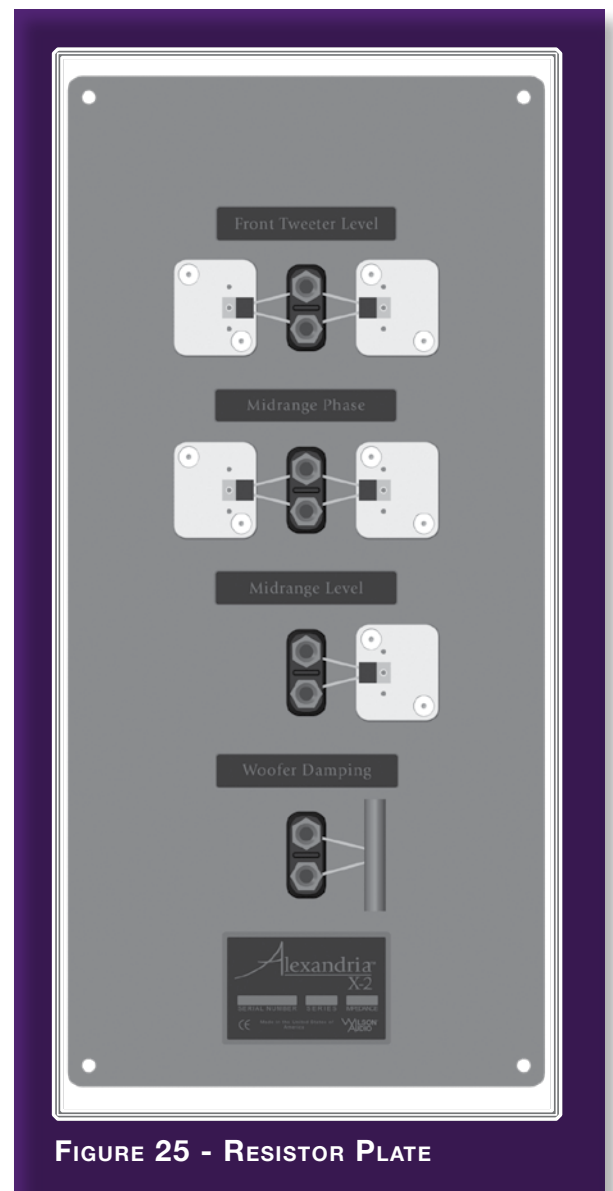

FIGURE 25 - RESISTOR PLATE

Section 4.11 – Break-in Period

All audio equipment will sound its best after its components have been broken in for some period of use. Wilson Audio breaks in all woofers and mid-range drivers for a 12 hour period. All drivers are then tested, calibrated, and matched for their acoustical properties. In your listening room, expect 25 to 50 percent of break-in to be complete after two hours of playing music fairly loudly. Ninety percent of break-in is complete after 24 hours of playing. Playing a “disc repeat” overnight can accomplish this task quickly. Wilson Audio recommends chamber music for this task.

SECTION 5 - CARE OF ALEXANDRIA X-2



Section 5.1 – Care of the Painted Finish

Your Alexandria Series 2 loudspeakers are hand painted with WilsonGloss™ paint and hand polished to a high luster. While the finish seems quite dry to the touch, final curing and complete hardening takes place over a period of several weeks. To protect the finish of the Alexandria during final manufacture, shipment, and setup in your listening room, we have applied a removable layer of protective film over the finish. We recommend that this film be left in place until the speakers are in their final location in your listening room. Once you have determined their final position, remove the film by peeling it off.



Do not leave this film on indefinitely as it may leave impressions on the paint.

It is important that the delicate paint finish of the Alexandria be dusted carefully with the dust cloth, which has been provided. We recommend that the following procedure be observed when dusting the speakers:

- Blow off all loose dust.
- Using the special dust cloth as a brush, gently whisk off any remaining loose dust.
- Shake out the dust cloth.

- Dust the finish, using linear motions in one direction parallel to the floor. Avoid using circular or vertical motions.

Because the paint requires a period of several weeks to fully cure, we recommend that no cleaning fluids, such as glass cleaners, be used during this initial period of time. When the paint is fully cured, heavy fingerprints and other minor smudges may be removed with a glass cleaner. Always use the dust cloth. Stronger solvents are not recommended under any circumstances. Consult your dealer for further information if required. To maintain the high luster of the finish, periodic polishing may be desired over the years. We recommend a nonabrasive carnauba-based wax and a soft cloth.

Care of the Grilles

Periodically, you will want to clean the Alexandria's. This is best done by using the round brush attachment on a vacuum cleaner hose. Gently vacuum the front surface of the grille. Be careful not to apply too much pressure. Do not use a hard plastic attachment against the grille. The grille cloth is stretched tightly over the grille frame. Too much pressure or use of a hard plastic attachment could cause the grille material to tear, especially in the corners.

Often Wilson speaker owners desire to change the look of their listening room by changing the color of their speaker grilles. In addition to basic black, Wilson Audio offers a variety of grille colors to



match most WilsonGloss finishes. Contact your local dealer for grille cloth samples or to order replacement grilles for your X-2 Alexandria.

Section 5.2 – Enclosure Construction

At the core of each Wilson Audio loudspeaker design is the knowledge that to achieve the best performance, you must start with the best materials. Here are a few of the elements that contribute to the Alexandria Series 2 enclosure's supreme performance.

Material

The Alexandria's low frequency enclosure is constructed from a high-density, phenolic resin based composite. This composite meets and exceeds the highest of ANSI test standards for its use, while offering very tight tolerances, high hardness, uniform density, and dimensional stability. In the construction of the Alexandria Series 2, Wilson Audio uses two types of composites dubbed "X" material and "M" material. These strategic combinations of X and M materials are used in the two midrange modules, resulting in the most inert enclosures yet produced. X material is used exclusively in the woofer and tweeter modules.

The high hardness of this composite not only offers excellent acoustical properties, but it also provides an ideal surface for painting.

Adhesive

Wilson Audio has conducted exhaustive research into the best adhesives to permanently bond our speaker enclosures. This is an often overlooked element crucial to the proper performance of a loudspeaker. Correct modulus of elasticity, coefficient of thermal expansion, and natural frequency response are just a few of the important elements of adhesives.

A highly cross-linked, thermoset adhesive is used for the construction of the enclo-

sure. It was also chosen for its excellent bond strength, solvent resistance, hardness, and optimum vibrational characteristics.

Conclusion

The combination of the best in composite materials and adhesive technology, provided to us by the leaders in their industries, allows us to design an enclosure with unmatched performance. The X-2 Alexandria's upper and lower cabinet modules have been designed to eliminate vibration and cabinet signature while maintaining an internal acoustical integrity. Wilson's exhaustive research into the effects of materials, enclosure construction strategies, and adhesives has yielded a product that maintains the strictest structural tolerances, durability, and reliability. The Alexandria's performance is repeatable and is unaffected by different climatic conditions throughout the world. The Alexandria X-2 Series 2 redefines the boundaries of what is possible in enclosure design.

SECTION 6 - TROUBLESHOOTING



One channel is not operating:

Check the interconnects from source.

Check the connections on the speaker cables, both at the amplifier and speaker ends. Watch especially for connectors touching each other.

Check the Upper Range Signal Cables. You may have forgotten to connect them, or they may have shorted or come loose during setup.

Imaging is off-center:

Check your connections. A connection to one of the modules may have come loose. When a tweeter or mid-range driver is not working, or is out of phase, the Alexandria will not “image” properly. Double check your connections for red-to-red and black-to-black.

Play music at a low level and listen to each driver in each channel. You may have a driver that is not operating correctly. If you find a driver that is silent, please go to the “Driver Out” section of this troubleshooting guide.

A chronic lack of bass energy:

Check the input cable connections on your woofer enclosure. If one channel is out of phase (connections reversed), bass will be cancelled. Note: Turn off your amplifier and unplug it from the wall.

Driver out or not playing after connections have been verified:

If you have found a driver with no output, move to the rear of this particular loudspeaker.

Remove the back cover exposing the

rear resistor plate. Locate the appropriate resistor. Loosen the binding post and remove the Allen bolt attaching the resistor to its heatsink. Replace the resistor with the supplied matching resistor.

Note: Use only Wilson Audio replacement resistors in your Alexandria. These resistors were carefully chosen for the overall sonic and thermal performance.

Plug your amplifier into the wall and turn it on.

Listen to the channel at a low level. The driver should now be operating correctly.

Amplifier shuts off as soon as it is turned on:

Check to see if your speaker cables are properly secured. Look for frayed ends, loose connections, or a conductor contacting the amplifier chassis.

Turn the amplifier off and disconnect it from the AC wall outlet. Disconnect the preamplifier leads to the amplifier. Now turn on the amplifier.

If the problem is solved:

There is likely something wrong with your preamplifier or interconnect. Contact your dealer.

If the problem persists:

Leave the preamp leads disconnected and continue to the next step.

Turn the amplifier off. Disconnect the speaker leads at the main input to the speaker. Now turn on the amplifier.

If the problem is solved:

Call your Wilson Audio dealer. There

may be a problem with the crossover or the speaker's internal wiring.

If the problem persists:

Continue to the next step.

Turn the amplifier off and disconnect it from the AC wall outlet. Disconnect the speaker cable leads to the amplifier and turn the amplifier on again.

If the problem is solved:

You have a short in your speaker cables. Check for frayed ends, holes (from spike feet), or make sure that your spade lug is not touching the chassis while it is connected to the binding post.

If the problem persists:

Call the dealer where you bought your amplifier. You appear to have a problem with this component.



SECTION 7 - SYSTEM SPECIFICATIONS

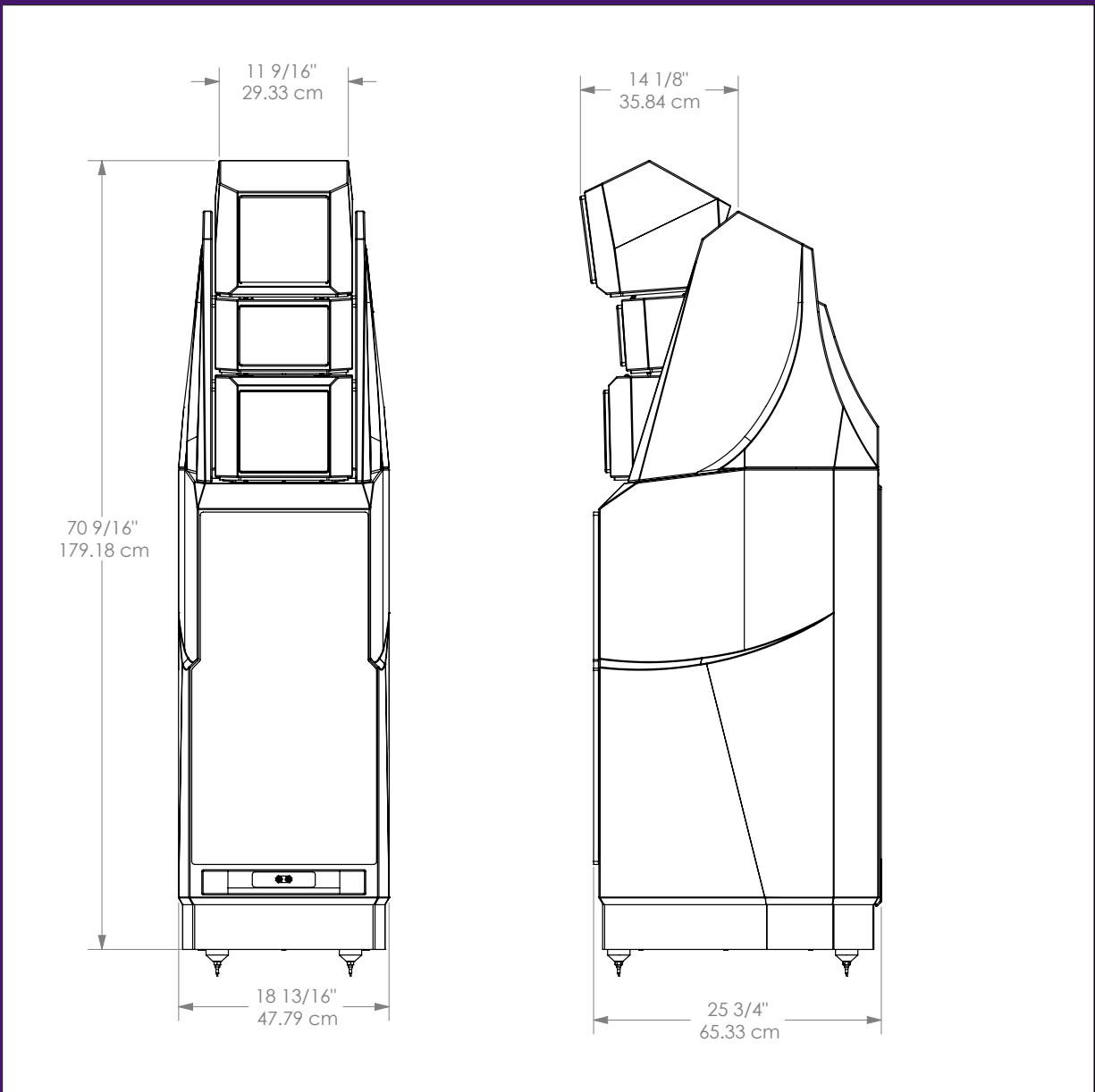

Section 7.1 – Specifications:

Enclosure Type Woofer: Front Ported

Enclosure Type Midrange: Rear Ported

Enclosure Type Tweeter: Sealed

Woofers: One – 13 inch, (33.0 cm)

One – 15 inch, (38.2 cm)

Midrange: Two – 6 3/4 inch (17.78 cm)

Tweeter: One – 1 inch inverted dome (2.54 cm)

Super Tweeter: One – 1 inch rear firing (2.54 cm)

Sensitivity: 95 dB@ 1 watt (2.83V at one meter)

Nominal Impedance: 4 ohms, 3 ohms minimal

Minimum Amplifier Power: 7 Watts per channel

Frequency Response: +0, -3 dB 19.5 Hz - 22.5 kHz

Average in-room response

Overall Dimensions: Height – 72 inches, (182.88 cm)

Width – 17 1/2 inches, (44.45 cm)

Depth – 27 3/4 inches, (70.49 cm)

System Weight Per Channel: 750 lbs each (340 kg)

Total System Shipping Weight (approx.): 2286 lbs pair (1037 kg)

Section 7.2 Alexandria X-2 Dimensions

FIGURE - 26

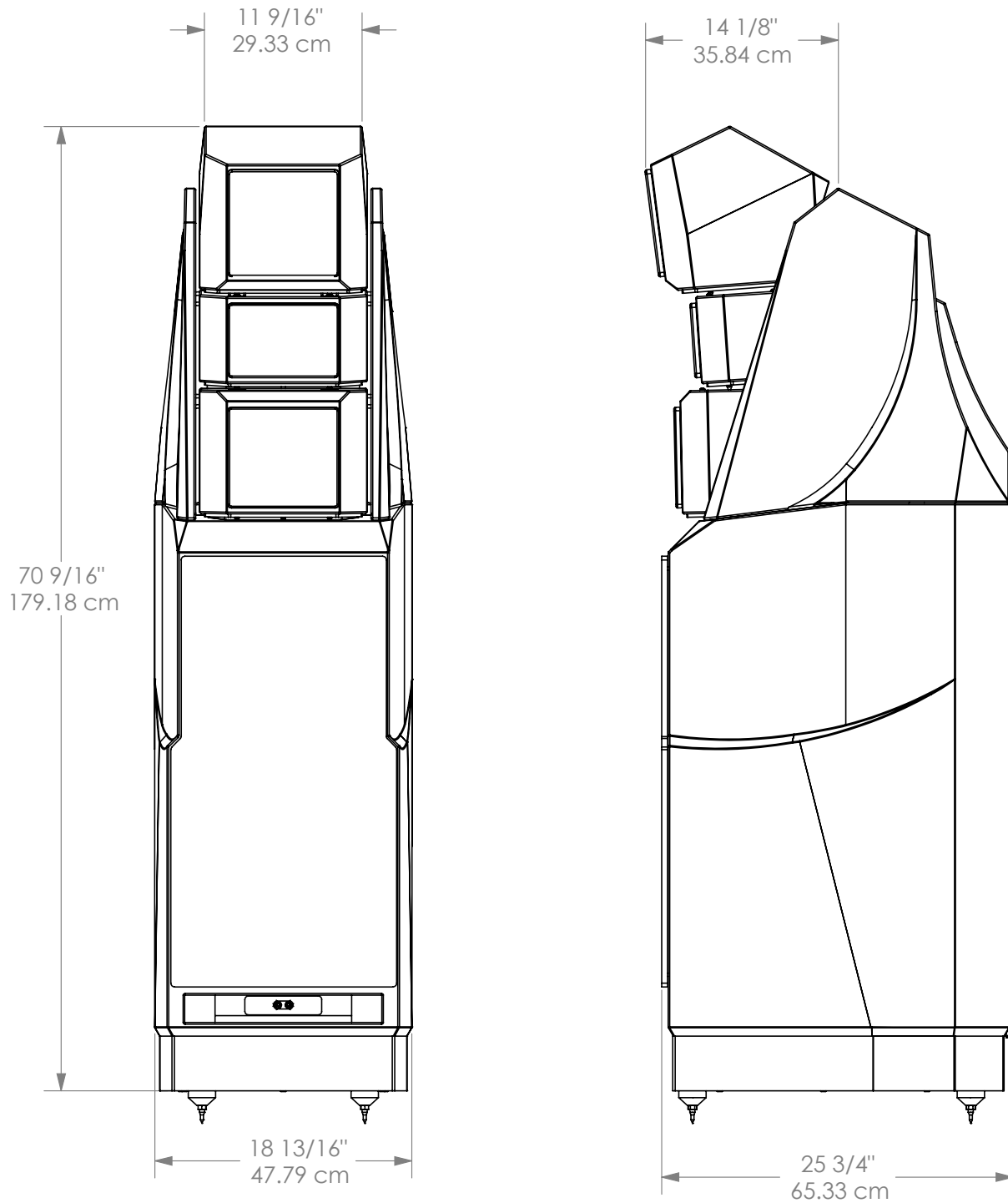

SECTION 8 - PROPAGATION DELAY TABLES

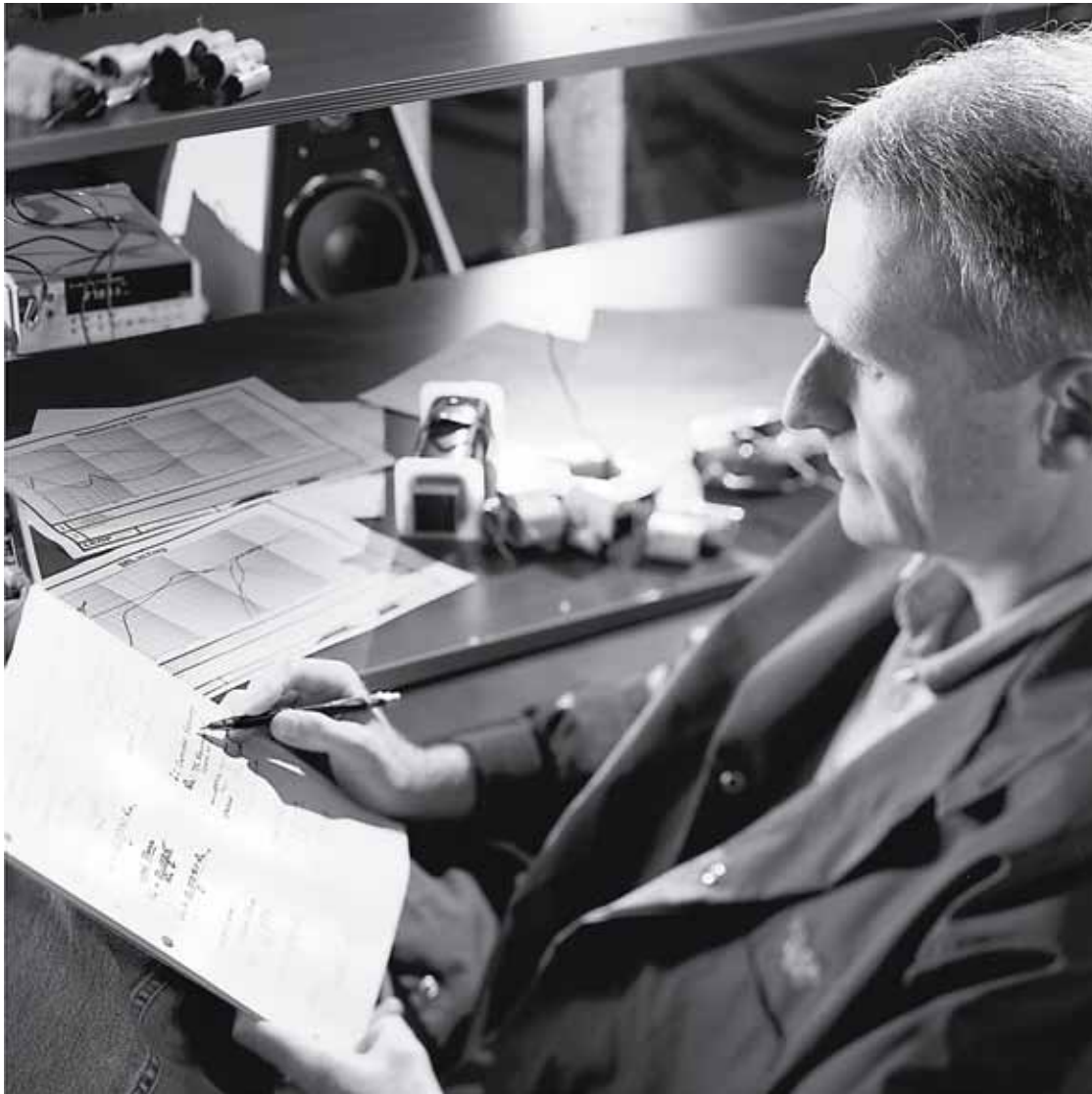

Lower Midrange Module Data												
Ear Height	Rear Spike Length											
48"	A	A	A	A	A	A	A	A	A	A	A	A
46"	B	B	B	B	B	B	B	B	B	B	B	B
44"	C	C	B	B	B	B	B	B	B	B	B	B
42"	C	C	C	C	C	B	B	B	B	B	B	B
40"	D	D	C	C	C	C	C	C	B	B	B	B
38"			D	D	D	C	C	C	C	C	B	B
36"				D	D	D	C	C	C	C	C	C
	8'	9'	10'	11'	12'	14'	16'	18'	20'	22'	24'	26'
Listening Distance (feet)												

Rear Spike Detent Location												
Ear Height	Rear Spike Detent Location											
48"	5	6	6	7	7	8	9	9	9	10	10	10
46"	7	8	8	9	9	9	10	10	10	11	11	11
44"	10	10	10	10	11	11	11	11	11	11	12	12
42"	12	12	12	12	12	12	12	12	12	12	12	12
40"	14	14	14	14	14	14	13	13	13	13	13	13
38"			16	16	15	15	15	14	14	14	14	14
36"				17	17	16	16	15	15	15	15	15
	8'	9'	10'	11'	12'	14'	16'	18'	20'	22'	24'	26'
Listening Distance (feet)												

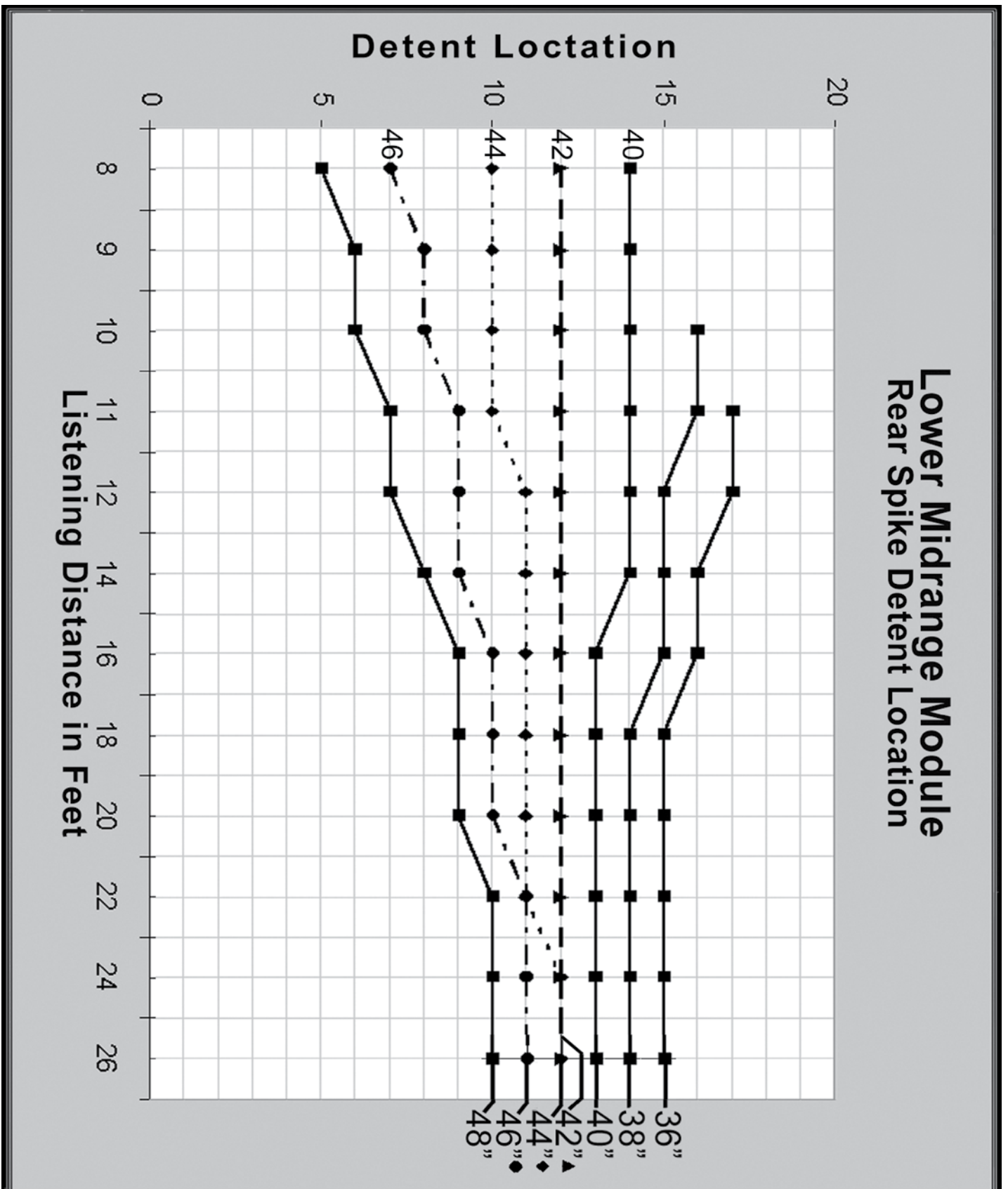

High Frequency Module Data

Ear Height	Rear Spike Length											
48"	C	C	C	C	C	B	B	B	B	B	B	B
46"	D	D	C	C	C	C	B	B	B	B	B	B
44"	D	D	D	D	C	C	C	C	B	B	B	B
42"	D	D	D	D	D	C	C	C	C	C	B	B
40"	D	D	D	D	D	D	C	C	C	C	C	C
38"			D	D	D	D	D	C	C	C	C	C
36"				D	D	D	D	D	D	C	C	C
	8'	9'	10'	11'	12'	14'	16'	18'	20'	22'	24'	26'
Listening Distance (feet)												

Ear Height	Rear Spike Detent Location											
48"	12	13	13	13	14	14	14	14	15	15	15	15
46"	16	16	16	16	16	16	16	16	16	16	16	16
44"	20	19	19	16	19	18	18	18	18	18	17	17
42"	23	23	22	22	21	20	20	20	19	19	19	19
40"	27	26	25	24	24	23	22	21	21	20	20	20
38"			28	27	26	25	24	23	22	22	21	21
36"				29	29	27	26	25	24	23	23	22
	8'	9'	10'	11'	12'	14'	16'	18'	20'	22'	24'	26'
Listening Distance (feet)												

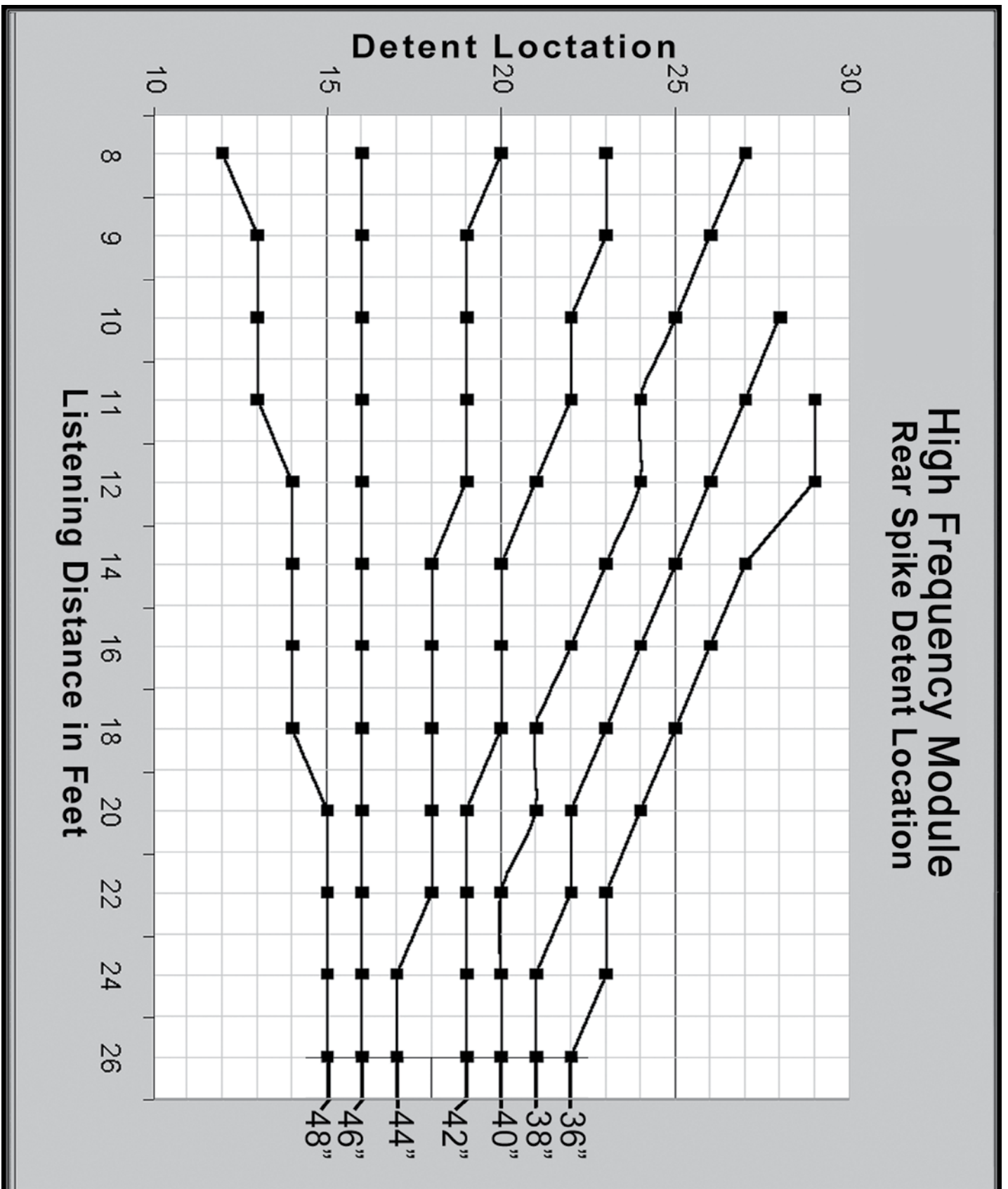

Upper Midrange Module Data												
Ear Height	Rear Spike Length											
48"	E	D	C	C	C	B	B	B	A	A	A	A
46"	E	E	D	D	C	C	B	B	B	B	B	A
44"	E	E	E	D	D	C	C	B	B	B	B	B
42"	E	E	E	E	D	C	C	B	B	B	B	B
40"	E	E	E	E	E	D	C	C	B	B	B	B
38"			E	E	E	D	C	C	C	B	B	B
36"				E	E	D	D	C	C	C	B	B
	8'	9'	10'	11'	12'	14'	16'	18'	20'	22'	24'	26'
Listening Distance (feet)												

Ear Height	Rear Spike Detent Location											
48"	8	7	7	6	6	6	5	5	4	4	4	4
46"	13	12	11	10	10	9	8	7	7	6	6	6
44"	19	17	15	14	13	12	10	9	9	8	8	7
42"	24	22	20	18	17	15	13	12	11	10	9	9
40"	29	26	24	22	20	18	16	14	13	12	11	10
38"			26	24	23	21	18	17	15	14	13	12
36"				27	28	24	21	19	17	16	15	14
	8'	9'	10'	11'	12'	14'	16'	18'	20'	22'	24'	26'
Listening Distance (feet)												

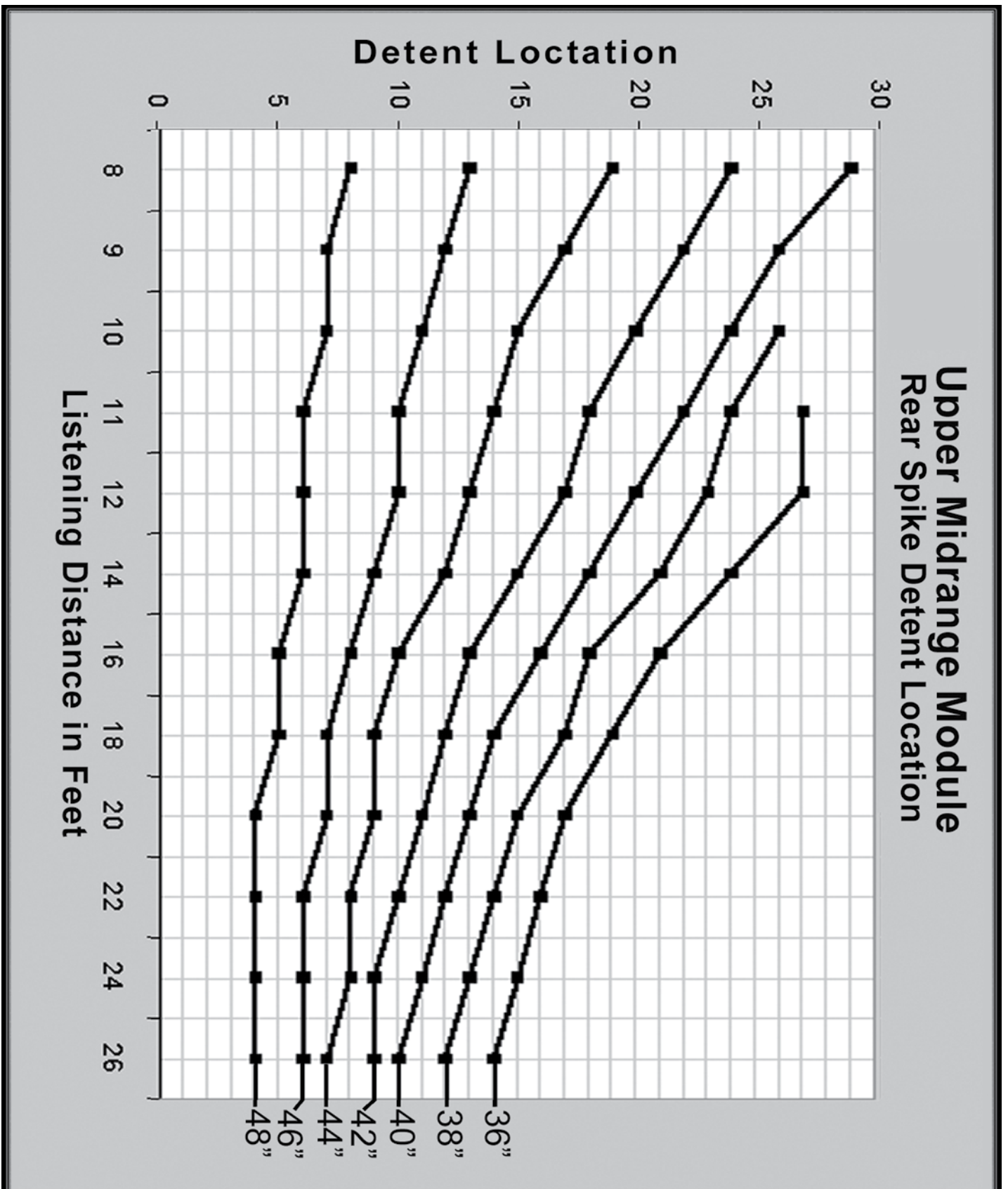

Lower Midrange Module Tether Bolt Table		
Spike Size	Tether Bolt Size	
	1	2
A	X	
B	X	
C	X	
D		X
E	NA	NA

High Frequency Tether Bolt Table		
Spike Size	Tether Bolt Size	
	1	2
A	X	
B	X	
C		X
D		X
E		X

Upper Midrange Module Tether Bolt Table		
Spike Size	Tether Bolt Size	
	1	2
A	X	
B	X	
C		X
D		X
E		X

SECTION 9 - WARRANTY INFORMATION



Section 9.0 – Warranty Information

Limited Warranty

Subject to the conditions set forth herein, Wilson Audio warrants its loudspeakers to be free of manufacturing defects in material and workmanship for the Warranty Period. The Warranty Period is a period of 90 days from the date of purchase by the original purchaser, or if both of the following two requirements are met, the Warranty Period is a period of five (5) years from the date of purchase by the original purchaser:

Requirement No. 1. No later than 30 days after product delivery to the customer, the customer must have returned the Warranty Registration Form to Wilson Audio;

Requirement No. 2. The product must have been professionally installed by the Wilson Audio dealer that sold the product to the customer.

FAILURE TO COMPLY WITH EITHER REQUIREMENT NO. 1 OR REQUIREMENT NO. 2 WILL RESULT IN THE WARRANTY PERIOD BEING LIMITED TO A PERIOD OF 90 DAYS ONLY.

Conditions

This Limited Warranty is also subject to the following conditions and limitations. The Limited Warranty is void and inapplicable if the product has been used or handled other than in accordance with the instructions in the owner's manual, or has been abused or misused, damaged by accident or neglect or in being transported, or if the product has been tampered with or service or repair of the product has been attempted or performed by anyone other than Wilson Audio, an authorized Wilson Audio Dealer Technician or a service or repair center authorized by Wilson Audio to service or repair the product. Contact Wilson Audio at (801) 377-2233 for information on location of Wilson Audio Dealers and authorized service and repair centers. Most repairs can be made in the field.

In instances where return to Wilson Audio's factory is required, the dealer or customer must first obtain a return authorization. Purchaser must pay for shipping to Wilson Audio, and Wilson Audio will pay for shipping of its choice to return the product to purchaser. **A RETURNED PRODUCT MUST BE ACCOMPANIED BY A WRITTEN DESCRIPTION OF THE DEFECT.** Wilson Audio reserves the right to modify the design of any product without obligation to purchasers of previously manufactured products and to change the prices or specifications of any product without notice or obligation to any person.

Remedy

In the event that the product fails to meet the above Limited Warranty and the conditions set forth herein have been met, the purchaser's sole remedy under this Limited Warranty shall be to: (1) contact an authorized Wilson Audio Dealer within the Warranty Period for service or repair of the product without charge for parts or labor, which service or repair, at the Dealer's option, shall take place either at the location where the product is installed or at the Dealer's place of business; or (2) if purchaser has timely sought service or repair and the product cannot be serviced or repaired by the Dealer, then purchaser may obtain a return authorization from Wilson Audio and at purchaser's expense return the product to Wilson Audio where the defect will be rectified without charge for parts or labor.

Warranty Limited to Original Purchaser

This Limited Warranty is for the sole benefit of the original purchaser of the covered product and shall not be transferred to a subsequent purchaser of the product, unless the product is purchased by the subsequent purchaser from an authorized Wilson Audio Dealer who has certified the product in accordance with Wilson Audio standards and requirements and the certification has been accepted by Wilson Audio, in which event the Limited Warranty for the product so purchased and certified shall expire at the end of the original Warranty Period applicable to the product.

Demonstration Equipment

Equipment, while used by an authorized dealer for demonstration purposes, is warranted to be free of manufacturing defects in materials and workmanship for a period of five (5) years from the date of shipment to the dealer. Demo equipment needing warranty service may be repaired on-site or, if necessary, correctly packed and returned to Wilson Audio by the dealer at dealer's sole expense. Wilson Audio will pay return freight of its choice. A returned product must be accompanied by a written description of the defect. Dealer owned demonstration equipment sold at retail within two (2) years of date of shipment to the dealer is warranted to the first retail customer to be free of manufacturing defects in materials and workmanship for the same time periods as if the product had originally been bought for immediate resale to the retail customer. Wilson Audio products are warranted for a period of 90 days, unless extended to 5 years, as provided above, by return and filing of completed Warranty Registration at Wilson Audio within 30 days after product delivery to customer and the product was professionally installed by the Wilson Audio Dealer that sold the product to the customer.

Miscellaneous

ALL EXPRESS AND IMPLIED WARRANTIES NOT PROVIDED FOR HEREIN ARE HEREBY EXPRESSLY DISCLAIMED. ANY LEGALLY IMPOSED IMPLIED WARRANTIES RELATING TO THE PRODUCT SHALL BE LIMITED TO THE DURATION OF THIS LIMITED WARRANTY. THIS LIMITED WARRANTY DOES NOT EXTEND TO ANY INCIDENTAL OR CONSEQUENTIAL COSTS OR DAMAGES TO THE PURCHASER.

Some states do not allow limitations on how long an implied warranty lasts or an exclusion or limitation of incidental or consequential damages, so the above limitations or exclusions may not apply to you. This Limited Warranty gives you specific legal rights, and you may also have other rights, which vary from state to state.

