

WILSON AUDIO PUPPY™



DIRECTIONS FOR CONNECTING THE PUPPY™

I. NORMAL CONNECTION WITH THE WATT (SEE FIGURE 1)

A. Connect the loudspeaker interface cables from the outputs of your amplifier to the "Main Input" of the Puppy. Use the included socket wrench to achieve a firm, but not overly tight, connection. For solid-state amplifiers, connect the positive (+) of the amplifier to the RED terminal. Connect the negative (-) of the amplifier to the black terminal. For tube amplifiers, connect the 4 ohm output tap of the amplifier to the RED terminal. Connect the common output tap to the black terminal.

IMPORTANT: Be sure that the supplied jumpers are attached between RED and BLACK terminal on the "jumper" connection.

B. Affix three damping discs onto the top surface of the Puppy, according to figure 3. These discs decouple subtle mid-range interface resonances.

C. Connect your WATT to the "high-pass output" terminals of the Puppy. Use the provided length of cable, making certain to orient the cable so that the arrow on the insulation points toward the WATT. Dress the cable through the channel in the back of the Puppy.

D. If desired, "fine-tune" the position of the WATT/Puppy for optimal sound quality in the listening environment. See the WATT Owner's Manual for placement tips on the WATT's. When the final location is determined, place pieces of tape on the floor at the corners of the Puppy's.

E. Remove the WATT from the Puppy, and carefully lay the Puppy on its side on a towel.

F. Loosely thread the nuts onto the eight (8) spiked feet. Position the nuts so that they line up with the top of the threaded area in the middle of the spike.

G. Thread the spikes into the base of the Puppy with washer between nut and base, so that they extend out the same length.

H. Set up the Puppies on their spiked feet at the originally determined location. At this point, do not yet place the WATT on the Puppy.

I. While pressing down on the top of the Puppy, try to "rock it on it's spikes" to see if they are all set at the correct length. If needed, adjust the extension of the spikes so that the Puppy is level and cannot be rocked. Using the 9/16" wrench (supplied), tighten the spike lock nuts.

J. Reposition and connect the WATT on top of the Puppy.

K. We recommend the use of the open foam grills on the WATT and the Puppy. When affixing them to the velcro strips, try not to stretch the foam. Lay it flat and gently on the strips, then tap it securely onto the velcro. (Line up the top edges first).

ALTERNATE CONNECTION

II. USE OF A SEPARATE AMPLIFIER TO DRIVE THE PUPPIES

(SEE FIGURE 2)

NOTE: Because of the extraordinary quality of the cross-over built into the Puppy, it is unlikely that the performance gains normally realized with an external electronic cross-over, and separate dedicated amps for the WATT and the Puppy can be achieved.

We definitely recommend the use of the internal cross-over if the Puppies are to be used with WATT's.

However, if another type of speaker is to be used with the Puppy, an external cross-over is likely to be necessary. This is because the Puppy's high-pass output circuit is optimized for the impedance characteristics of the WATT. Most other speaker's impedance curves differ enough from the

WATT's (and from each other) that they will not produce the desired low frequency roll-off.

The target roll-off point should be in the 110 Hz to 150 Hz region, depending on the satellites low frequency output level and power-handling.

A. Referring to Figure 2, connect the amplifier interface cable for your upper range amplifier directly to your upper range speaker's input terminals.

B. Connect the amplifier interface cable from your low frequency amplifier to the "Direct Connection" input on the left side of the Puppy's connector plate.

C. Make sure that the jumper is **NOT** connected.

D. Finish the placement/set-up of your system according to the guidelines from section I-B to section I-K. (The "WATT Owner's Manual" has also proven itself to be invaluable for placement/set-up).

Thank you for your use of Wilson Audio products.

ALTERNATIVE CONNECTION

Figure 2

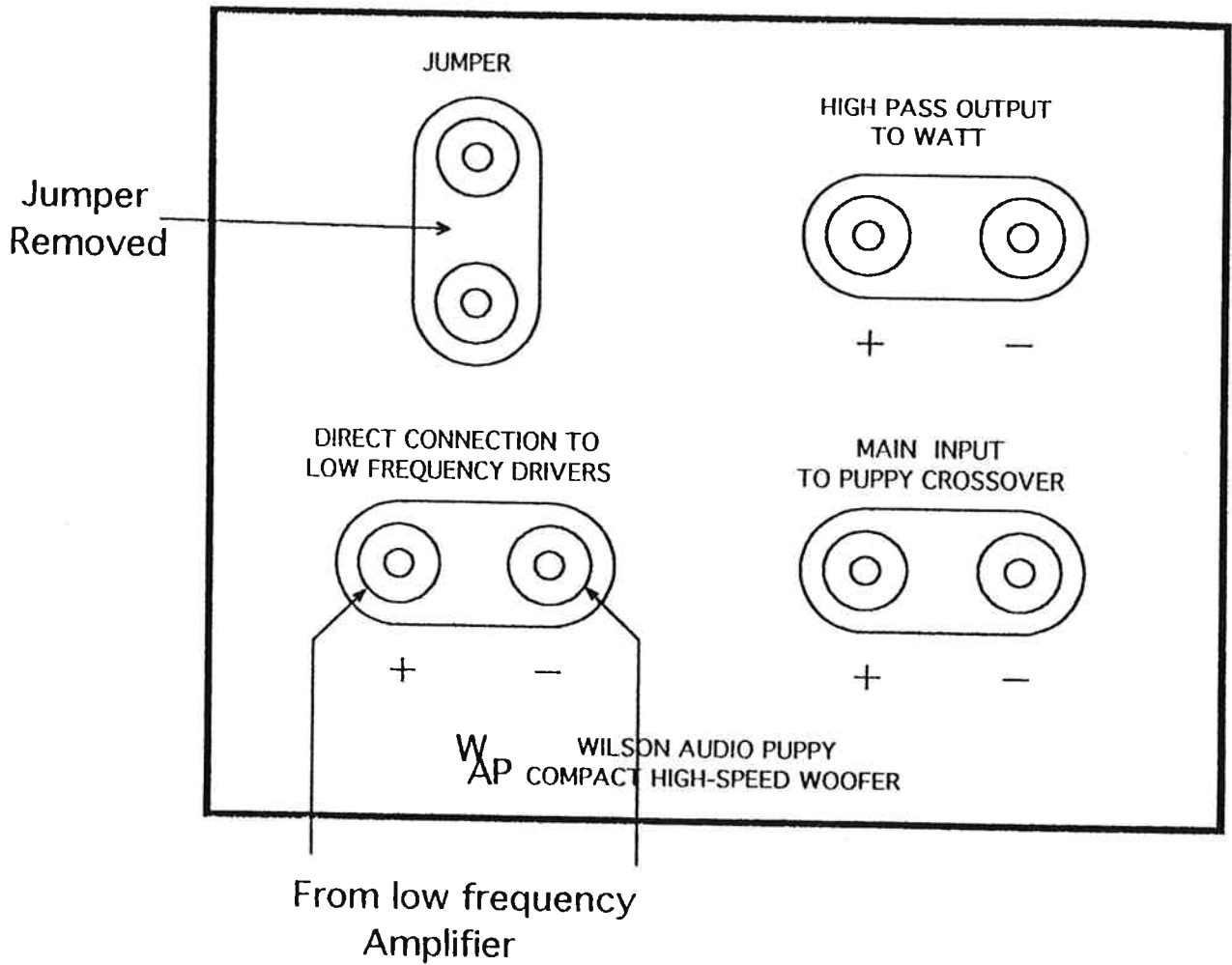

Alternative connection, using external electronic crossover and separate amplifiers for PUPPY and "satellite".

NOT recommended when using WATT.



PLACEMENT OF BITUMINOUS DISCS

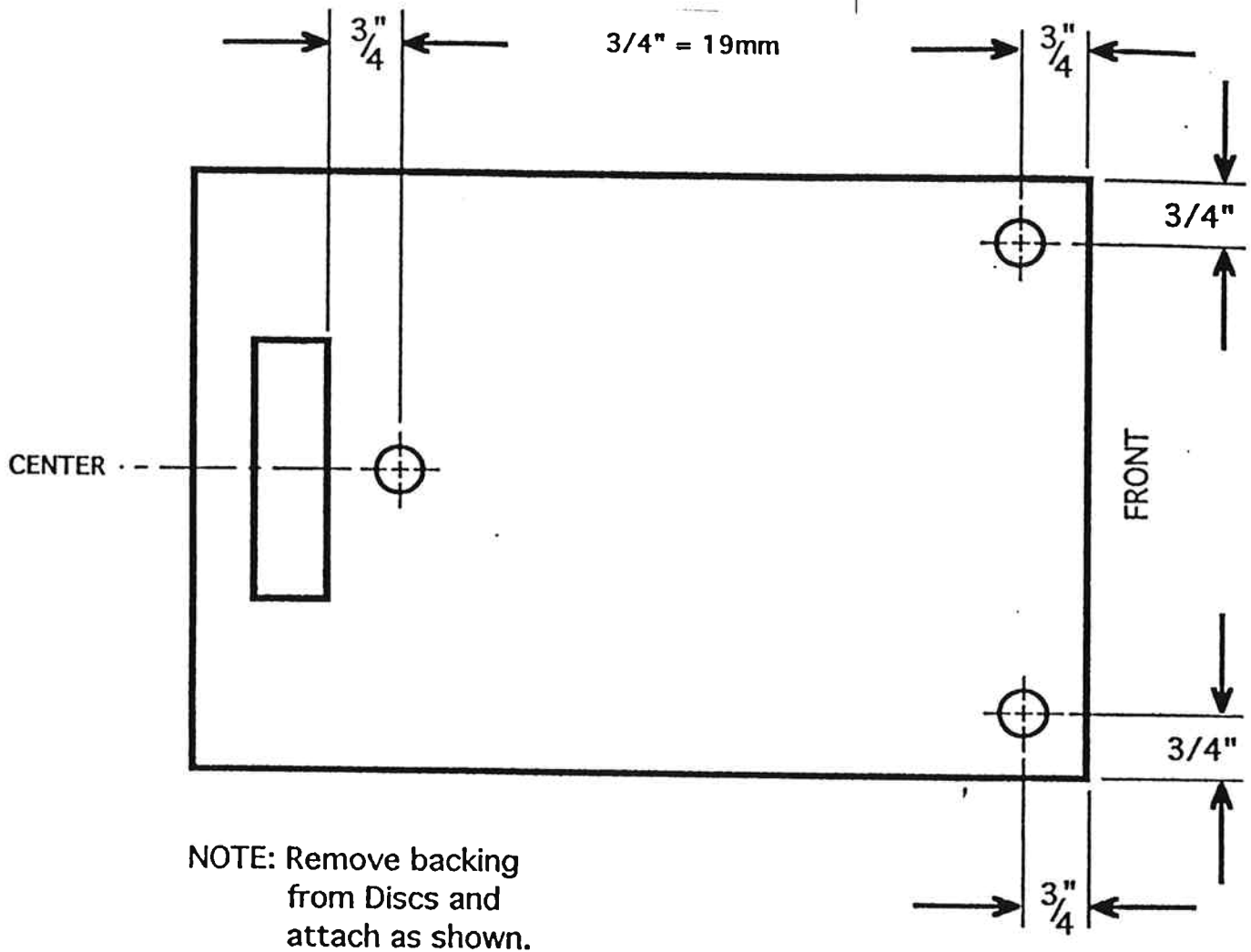

NOTE: Remove backing from Discs and attach as shown.

NORMAL CONNECTION TO PUPPY™ WHEN USED WITH WATT™

Figure 1

