

Autobiography™



INSTALLATION AND CARE GUIDE

WILSON
AUDIO

WA DEALERS



Wilson Audio® is a registered trademark of Wilson Audio Specialties, Inc.

Wilson Audio (Stylized)®, WAMM®, Master Chronosonic®, WAMM Master Subsonic®, Chronosonic XVX®, Alexx®, Alexx V®, Alexia®, Alexia V®, Sasha DAW®, The WATT/Puppy®, Sabrina V®, SabrinaX®, Alida®, TuneTot®, LōKē®, Submerge®, Pedestal®, Wilson Audio Acoustic Diode®, Reliable Capacitor®, Rel-Cap®, AudioCap®, AudioCapX®, IsoBase®, Wilson Audio Authentic Excellence®, Wilson Audiophile Recordings LLC®, and Special Applications Engineering® are registered trademarks of Wilson Audio Specialties, Inc.

Autobiography™, Chronosonic XVX 4 Seasons™, Alexandria™, Alexandria XLF™, X-1™, X-2™, Grand SLAMM™, MAXX™, Sasha V™, Sasha W/P™, WATT™, Puppy™, WATT/Puppy™, Sabrina™, Yvette™, Sophia™, WITT™, Duette™, CUB™, Alida CSC™, Polaris™, Mezzo™, WASAE Center™, WATCH Center™, WATCH Surround™, XS™, Thor’s Hammer™, WHOW™, WATCH Dog™, ActivXO™, WATCH™, Excellence in All Things™, Certified Authentic™, It’s About Time™, WilsonGloss™, Convergent Synergy Carbon™, PentaMag™, QuadraMag™, X-Material™, S-Material™, H-Material™, and V-Material™ are trademarks of Wilson Audio Specialties, Inc.

This manual was produced by the Wilson Audio Engineering and the Marketing Departments. The information contained herein is subject to change without notice.

Current Revision 2.0. If you are in need of a more recent manual, please contact your Dealer or download one at www.wilsonaudio.com.

The information in this manual is the sole property of Wilson Audio Specialties, Inc. Any reproduction, in whole or in part, without the express written permission of Wilson Audio Specialties, Inc., is prohibited. No material contained herein may be transmitted in any form or by any means, electronic or mechanical, for any purpose, without the express written permission of Wilson Audio Specialties, Inc.

Copyright © 2026 Wilson Audio Specialties, Inc.

Autobiography

2 AUTOBIOGRAPHY INSTALLATION AND CARE GUIDE

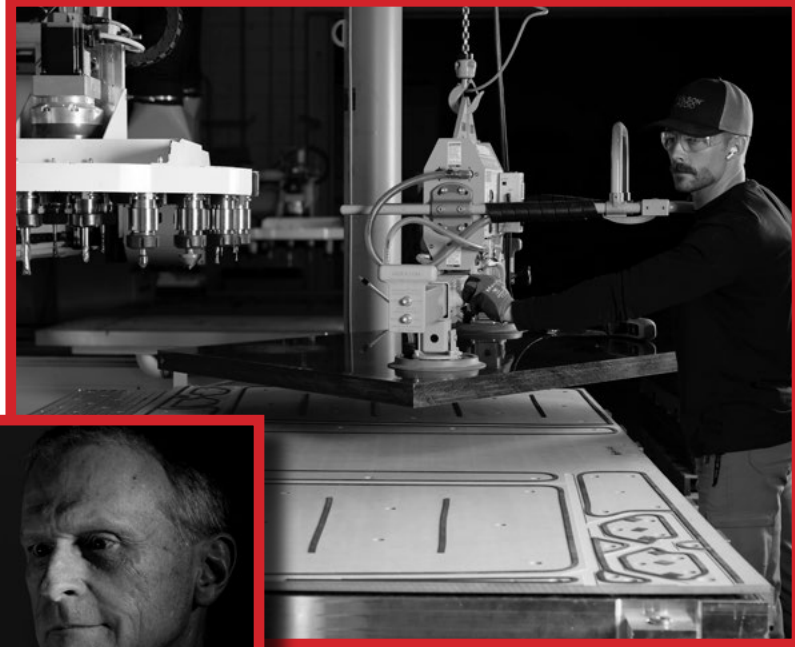

AUTHENTIC EXCELLENCE

C O N T E N T S

SECTION 1—WASP SETUP.....	5
SECTION 2—UNCRATING & SPIKING	13
SECTION 2.1—UNCRATING AUTOBIOGRAPHY	14
SECTION 2.2—SPIKING AUTOBIOGRAPHY	16
SECTION 2.3—WRAPPING FOR RE-SHIPPIING	20
SECTION 3—ASSEMBLY	23
SECTION 3.1—AUTOBIOGRAPHY AND THE TIME DOMAIN ..	24
SECTION 3.2—GATHER NOMOGRAPH MEASUREMENTS.....	25
SECTION 3.3—INSTALLING THE GANTRY	26
SECTION 3.4—INSTALLING THE UPPER MODULES.....	29
SECTION 4—CONNECTING THE MODULES	37

4 AUTOBIOGRAPHY INSTALLATION AND CARE GUIDE

SECTION 5—FINAL SETUP	41
SECTION 5.1—INSTALLING AUTOBIOGRAPHY	42
SECTION 5.2—ADJUSTING THE XLF PORT	43
SECTION 5.3—REAR FIRING TWEETER (RFT) ATTENUATOR....	45
SECTION 5.4—LEVELING AUTOBIOGRAPHY	47
SECTION 5.5—REMOVING THE PROTECTIVE FILM	48
SECTION 5.6—RESISTORS	49
SECTION 6—SPECIFICATIONS	55
SECTION 7—TIME ALIGNMENT CHARTS	61
SECTION 8—WARRANTY	67

SECTION 1—WASP SETUP

SECTION 1—WASP

An instructional video outlining the **Wilson Audio Setup Procedure (WASP)** can be found here by scanning the QR code or by visiting: www.wilsonaudio.com/wasp

The proper positioning of Autobiography within your room is critical in order to extract its formidable performance envelope. When carefully followed, the WASP has proven to be the most effective method for setting up Wilson Audio loudspeakers. Your authorized Wilson Audio Dealer is trained in this process, and is the best resource for you to ensure your loudspeakers are setup properly.

Viewing the video is the best way to learn how to properly employ WASP, but we have also included a simplified outline.

Zone of Neutrality: Left and Right Channel

The “Zone of Neutrality” is an area in your room where the speakers will sound most natural. In this location is where the speakers interact the least with adjacent room boundaries. It is important to have a clear working space while determining the Zone of Neutrality.

The following is a simple method to locate the Zone of Neutrality within your listening environment:

1. Stand against the wall **BEHIND** the location where you intend to position your loudspeakers. Speaking in a moderately loud voice and at a constant volume, project your voice out into the room towards the listening chair. Your voice will have an overly heavy, “chesty” quality because of your proximity to the rear wall.
2. While speaking, slowly move out into the room, progressing in a direction parallel to the sidewall. It is helpful to have another listener seated in the listening position to assist you during this process. Listen to how your voice “frees up” from the added bass energy imparted by the rear wall boundary. Also, notice that your voice is quite spatially diffuse (to



WASP VIDEO

your assistant, your voice will sound spatially large and difficult to localize) as you begin to ease away from the rear wall.

3. At some point during your progression forward into the room, you will observe a sonic transition in your voice; this will sound more tonally correct and less spatially diffuse (your assistant can now precisely localize the exact origin of your voice). When you hear this transition, you have entered the inner edge of the Zone of Neutrality. Place a piece of tape on the floor to mark this location. Although it will vary from room to room, in most rooms the zone begins between two and a half to three feet from the rear wall.
4. Continue to walk slowly away from the rear wall. After some distance, usually one to two feet past the first piece of tape, you will begin to hear your voice lose focus and appear to reflect or “echo” in front of you. This is caused by the return of the room’s boundary contribution; your voice is now more noticeably interacting with the opposite wall. At the point where you begin to hear the reflected sound of your voice, you have reached the outer edge of the Zone of Neutrality. Place a piece of tape on the floor and mark this location. The distance between the “inner” and “outer” edge tape marks is usually between eight inches (for small, interactive rooms) and three feet (for large, more neutral rooms).
5. Now position yourself against the side wall perpendicular to the intended speaker location. Stand between the two tape marks. Using the same procedure as above, begin moving into the room toward the opposite sidewall, progressing between the two pieces of tape. As explained, listen for the point in the room where your voice transitions from bass-heavy and diffuse to neutral. Mark this point with tape. Continue your progression until there is an obvious and distracting interaction with the wall in front of you and mark this point with tape. The four pieces of tape now form a rectangle that establishes the Zone of Neutrality for the loudspeaker to be installed on that side of the room.

8 AUTOBIOGRAPHY INSTALLATION AND CARE GUIDE



When carefully followed, the WASP has proven to be the most effective method for setting up Wilson Audio loudspeakers.

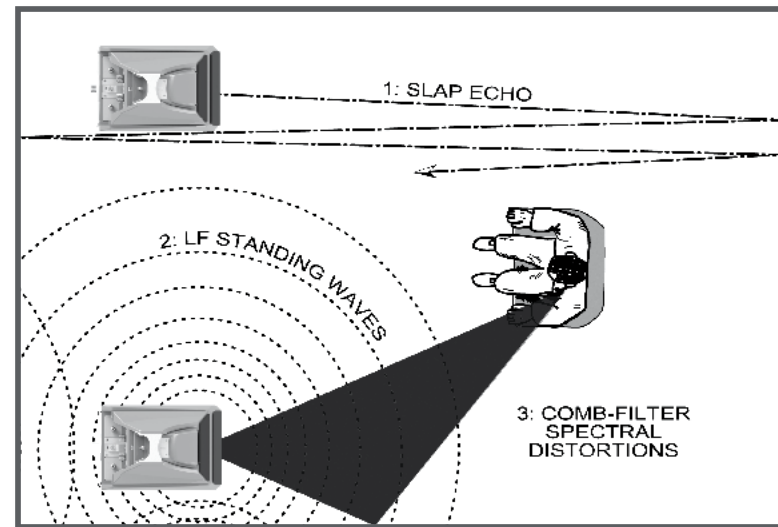

6. Repeat this process for each speaker location individually. These are your Zones of Neutrality, one for each channel.

Theoretically, the Zone of Neutrality for any room runs like a path parallel to the walls all around the room. Adjacent to very large windows and open doors, the outer edge of the Zone of Neutrality moves closer to the wall and becomes wider. If you were to extend the “inner” and “outer” boundaries of the Zone for the side-walls and the front wall (behind the speakers), they would intersect.

Move to Section 2 “Uncrating & Spiking” now.

Speaker Placement Versus Listening Position

Return to this section after you have uncrated and placed the assembled Autobiography in the Zone of Neutrality.

The location of your listening position is as important as the careful setup of your Wilson Audio loudspeakers. A guideline, but not a fixed rule, states the listening position should ideally be no more than 1.1 to 1.25 times the distance between the Tweeters on each speaker. Therefore, in a long, rectangular room of 12' x 18', if the speaker Tweeters are going to be 9' apart, you should be sitting roughly 9'11" to 11'3" from the speaker. This would be more than halfway down the long axis of the room.

Many people place the speakers on one end and sit at the other end of the room. This approach will not yield the finest sound and is not recommended. Carefully consider your listening position. Our experience has shown that any listening position that places your head closer than 14" from a wall, or exactly in the center of a room, will diminish the sonic results of your listening due to the deleterious effects of boundary interaction.

Speaker Orientation

Speaker placement and orientation are two of the most important considerations in obtaining superior sound. The first thing you need to do is eliminate the sidewalls as a sonic influence in your system. Speakers placed too close to the sidewalls will suffer from a strong primary reflection. This can cause out-of-phase cancellations, or “comb filtering,” which will cancel some frequencies and change the tonal balance of the music. Adhering to the Wilson Audio Setup Procedure outlined in this Section, and as shown in the instructional video, is the best method to position your loudspeakers.

A very important aspect of speaker placement is how far from the back wall to place the speakers. The closer a loudspeaker is to the back wall, the more pronounced the low bass energy and centering of the image will be. However, this comes at a definite reduction in soundstage size and bloom, as well as a degradation of upper bass quality. You must find the proper balance of these two factors, but remember, if you are partial to bass response or air and bloom, do not overcompensate your adjustments to maximize these effects. Overcompensated systems are sometimes pleasing in the short-term, but long-term satisfaction is always achieved through proper balance as explained.

Once this installation process is complete no more Module adjustments are necessary. The Wilson Way WASP Speaker Calibration Form has been included to assist in the installation and sonic fine-tuning process, it can be found on page 11. All documentation should be duplicated: the Dealer should keep one set for future support and the owner should keep one set in an easy to retrieve location.



SECTION 2—UNCRATING & SPIKING

Note: You will have two channels to unpack with several enclosures per channel. The two channels will need to be separated into right and left spaces. Clear out two spaces in your room, one for your Left and one for your Right channels. For channel matching, place the ODD numbered enclosures in the LEFT channel position and the EVEN numbered enclosures in the RIGHT channel position.

Note: Please remove any jewelry such as rings, watches, necklaces, and bracelets (along with covering belt buckles and zippers) during this process to avoid damaging any of the painted or metal surfaces.

SECTION 2.1—UNCRATING AUTOBIOGRAPHY

Initial Check

Autobiography is shipped in a total of six banded/strapped crates. Upon receiving these crates, please check their condition. If any of the crates are damaged, please report it to the shipping company immediately for insurance verification.

The following items are recommended for this procedure:

- Suitable Tool to cut the Straps around Crates
- Electric Drill with Phillips Head Bit

Uncrating Autobiography

Note: A minimum of four to five strong adults are required to set up Autobiography safely.

1. Using your preferred cutting tool, carefully cut the bands around the crates.
2. With the crates facing up, remove the screws securing the crate lids and set the crate lids out of the setup area.

The first crate you should open is the Treasure Chest which contains the essential tools needed for installation and setup of the Autobiography system. Included in this crate:

- Autobiography Owners Manual with Installation Card
- Tool Kit (Tool Kit Map shown on page 17)
- (2x) Embroidered Wilson Audio Installation Blankets (floor protection)
- Wilson Audio Aluminum Slider Set (boxed set)
- Acoustic Diode Set (boxed set)
- Wilson Audio Jack and Wrench
- Wilson Audio Caster Bag (store casters in after installation)
- *Other various printed material - Full Line Brochure, Warranty Registration Form, Wilson Audiophile Recordings Leaflet, etc.*

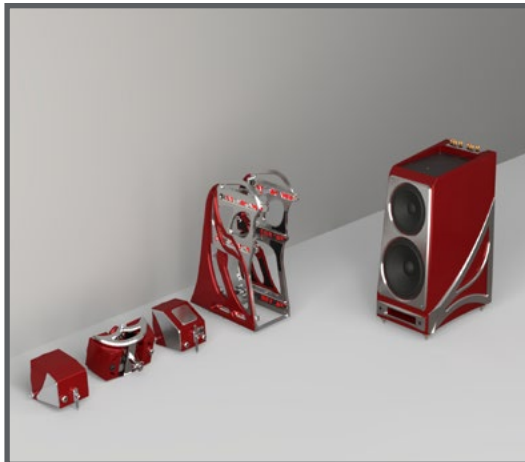

3. Remove and organize all the contents from the Treasure Chest and place in a safe, easy-to-retrieve location. Spread the installation blankets over the floor in the work area, do not cover any of the Zone of Neutrality.

Note: The Autobiography is extremely heavy and care should be taken to prevent injury while uncrating/rolling/moving the Autobiography enclosures into the marked Zone of Neutrality.

4. Next unpack the Woofer enclosures. Carefully lift the crate upright (if it is not already) so that the Woofer enclosure is now vertical, the bottom of the Autobiography is now toward the floor. **Using the lid as a ramp**, one person will hold the crate while the other installers reach in and gently roll the Autobiography Woofer enclosure out of the crate.

5. Place the Woofer enclosures in the marked Zones of Neutrality as described in Section 1. The Woofer baffle should start 2/3 the way into the ZoN, closest to the listening position. Remove the Woofer grilles from their plastic bags and place the grilles in a safe location out of the working space.

Note: The Autobiography Upper Modules do not have grilles. Be careful not to touch the driver diaphragms as the enclosures are unpacked and moved.

6. Unpack the Upper Module crates and carefully lift the Upper Modules out of the crates. Place them in the correct working space for the Left/Right channels, drivers facing the wall. (*See staging graphic on previous page*)
7. Unpack the Gantry crates and carefully lift them into the correct channel location according to the staging graphic.

Note: After the system is set up, keep the shipping crates for future shipping needs.

At this point, all of the Autobiography enclosures and tools needed to install the system are now laid out and organized in the listening space. You are now ready to spike the Woofer enclosures on Sliders.

SECTION 2.2—SPIKING AUTOBIOGRAPHY

Most authorized Wilson Audio Dealers use the Wilson Audio metal “Sliders” which allows the speaker to be spiked and moved easily during the installation process. Autobiography includes a set of Sliders for ease of installation. A fully assembled Autobiography is very heavy. We recommend installing the Spikes and use the Sliders before the Gantry and Upper Modules are attached. If the installation surface does not accommodate the use of Sliders, installation can proceed with the use of casters instead. Final leveling will be addressed at the end of the installation process.

**You will be using tools/parts from this kit throughout the installation process.
Keep the Autobiography Tool Kit close by.**

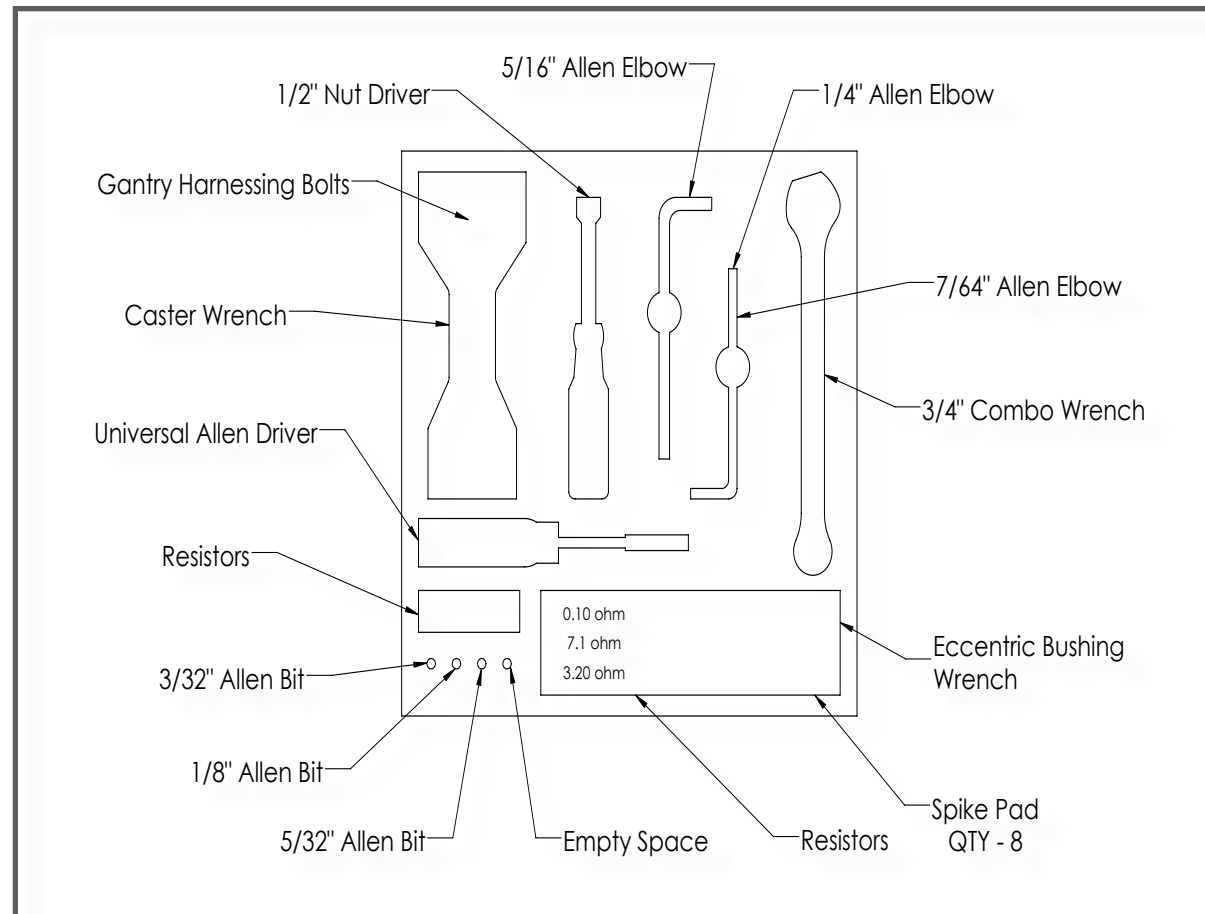



Spike & Diode Assembly (Wilson Audio Acoustic Diode)

1. Gather the threaded Spikes and install the Nut to about two threads from the unthreaded Spike tip. This will allow for greater movement when leveling the loudspeaker later.
2. Screw the Spike + Nut combo into the diode housing until the Nut is against the Diode.

Note: Do not tighten the Nut against the Diode yet. You will need to unscrew them when you level the Autobiography later.

3. Thread the Set-Screw into the other end of the Diode (V-Material side) with the Allen head toward the Spike. This will ensure that, if for any reason you have to remove the Spikes, you will be able to withdraw the Set-Screw safely using the supplied Allen wrench.
4. Place the Spike & Diode assemblies out of the traffic pattern until they are needed during the installation.

Note: Be very careful not to cross-thread the Spike & Diode assembly. The base of the Autobiography where the threads engage the enclosure is made of a V-Material and X-Material hybrid and can be cross-threaded if the Spike & Diode assembly is installed at an angle.

Note: Installing the Spike & Diode assemblies is a two person job. Do not attempt this by yourself. Autobiography is heavy and may seriously injure someone if tipped over. An assistant should stand to the rear of the Autobiography to steady it.

Materials Required

- (8x) Wilson Audio Acoustic Diode (assembled)
- Wilson Audio Jack and Wrench
- Wilson Audio Aluminum Slider Set (boxed set)
- Caster Wrench
- Wilson Audio Caster Bag (store casters in after installation)

Acoustic Diode Installation Procedure

1. Take care to mark the exact location of the Autobiography's with masking tape to ensure the speakers can be returned to their exact setup position.
2. Use the Wilson Audio Jack and Wrench to lift the front of the speaker high enough to remove the Casters. Use the Caster Wrench to remove the front two Casters and place them in Caster Bag.
3. Insert the assembled Acoustic Diodes into the same two threaded holes located on the front bottom of the Autobiography. Tighten until the top surface of the Acoustic Diode V-Material touches the bottom surface of the Autobiography.

Note: Hand tighten only.

4. Taking care to observe the location of the Autobiography relative to the masking tape used during the WASP documentation. Return the Autobiography to the precise location marked on the ground. Note that if the Sliders are not used under the Spikes the Autobiography will sit lower in the front as the Spike assembly is shorter than the caster. Use caution if Sliders are not used in this installation.
5. Repeat spiking process on the rear two Caster locations on the bottom back of the loud-speaker.

Note: It is very important, at this point, that an able assistant stabilize the front of the Autobiography until the rear Acoustic Diodes are attached and the unit is lowered.

6. Repeat entire spiking process on the other Autobiography.

At this point refer to Section 5.5 and remove the frisk from the Upper Modules. Once the system is fully assembled it will be difficult to access the frisk on the Upper Modules while in the Gantry. Since moving the assembled channel is still a part of future installation steps, we recommend keeping the frisk on the Woofer enclosure until the system is spiked to the floor/carpet in its final position.

SECTION 2.3—WRAPPING FOR RE-SHIPPING

Note: Please contact your authorized Wilson Audio Dealer for help with this process.

When a Wilson Audio speaker is shipped new from the factory, there is a protective film applied called “frisk” which is peeled and removed upon installation.

When someone ships an un-frisked speaker they must recreate the protective layer so the paint and hardware are not damaged.

1. Clean the painted surface of all dust and contaminants using the Wilson Audio WilsonGloss Detail Kit (found on Wilson Audio's on-line store) or a 3M 39015 Perfect-It Show Detailing Cloth. Be gentle and lightly brush in one direction and not in a circular motion to reduce the risk of scratching the paint. If there are contaminants still on the paint, they can be removed with a lightly moistened 3M cloth, or a detailing spray such as Star Brite Ultimate Matte Finish.
2. Place grilles on each section of the speaker.
3. Use stretch/cling (or Saran wrap) to gently wrap each section 3-4 times to cover the painted surface and hardware to prevent rub marks. Once the stretch film is applied you can then safely place the speakers in the crates.
4. The bags can go over the top of your stretch wrap layers. The plastic bags alone will not protect a painted surface during transport.

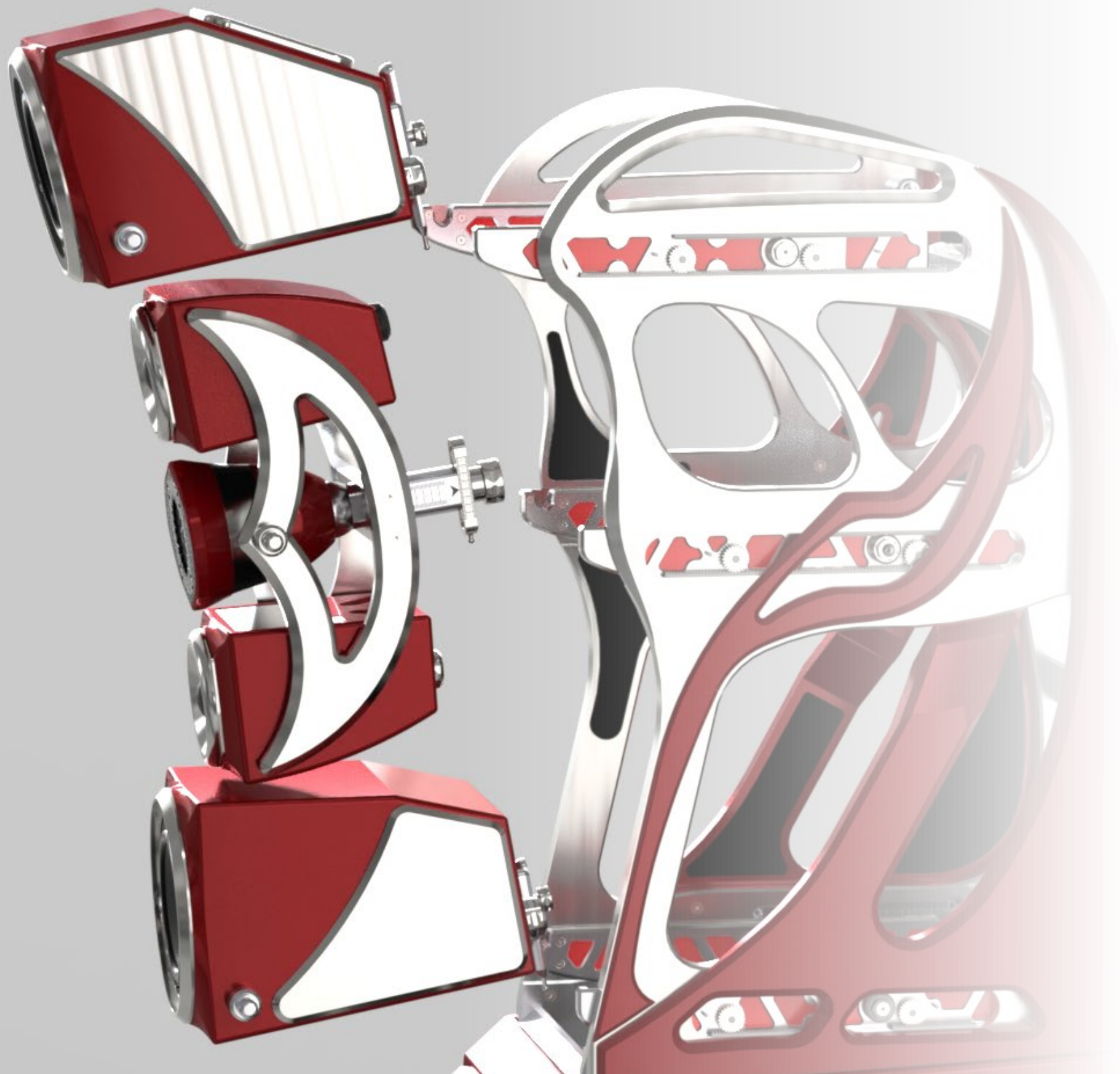

SECTION 3—ASSEMBLY

SECTION 3.1—AUTOBIOGRAPHY AND THE TIME DOMAIN

General Description

The Autobiography incorporates newly developed hardware that enables faster, more precise, and more intuitive time-domain alignment than any previous loudspeaker design. Previous Wilson Audio systems relied on combinations of captive spikes, ball posts, interchangeable spike sets, and stepped blocks to position Upper Modules. All of these options required more time setting the system up and complications if major adjustments were needed in the future. The Autobiography introduces an integrated Slide Spike System that simplifies Module adjustment while significantly increasing accuracy. The system may be adjusted whether the loudspeaker is fully assembled or partially disassembled. The Slide Spike and Module Alignment Sled work together to rotate the Upper Modules into the exact time-alignment position specified in the Nomograph section of this Owner's Manual.

The dual 2" Midrange Modules and the Tweeter Module form a unified subassembly referred to as the MTM Alignment Assembly. These Modules move in tandem to preserve their acoustic relationship. The MTM Alignment Assembly is mounted to the Module Alignment Sled. The overall submodule angle is adjusted via the MTM Precision Rear Slide Spike hardware. Dedicated Tweeter Alignment Hardware allows precise adjustment of the Tweeter baffle relative to the two 2" Midrange drivers within the MTM assembly. This dual-stage approach enables both macro time alignment (entire MTM assembly) and micro alignment (Tweeter-to-Midrange relationship).

Each 7" Module incorporates a rear-mounted Slide Spike that allows controlled angular adjustment toward the listening position. Both 7" Modules and the MTM Alignment Assembly are smoothly positioned in the fore-aft axis using the Alignment Sled's Rotating Cam Grip mechanism. This provides continuous, controlled movement without stepped indexing.

When properly adjusted, the Autobiography functions as an acoustically coherent system. Like precisely focused lens elements in a camera, each Module is positioned so that the acoustic wavefronts from all drivers converge at the listening position simultaneously. This time-aligned convergence allows the recording's spatial information, transient structure, and harmonic integrity to be reproduced with exceptional realism.

SECTION 3.2—GATHER NOMOGRAPH MEASUREMENTS

Optimizing Propagation Delay in Your Room

The Autobiography system allows optimization for different listening distances and listening ear heights. In order to calculate the proper time-domain settings for the Upper Modules, the distances from the listener's ear to the front, lower baffle of the Autobiography (*see graphic below*), and the distance from the floor to the listener's ear must be accurately measured. For each distance/ear height combination there is a unique alignment geometry and unique hardware settings provided in Section 7.

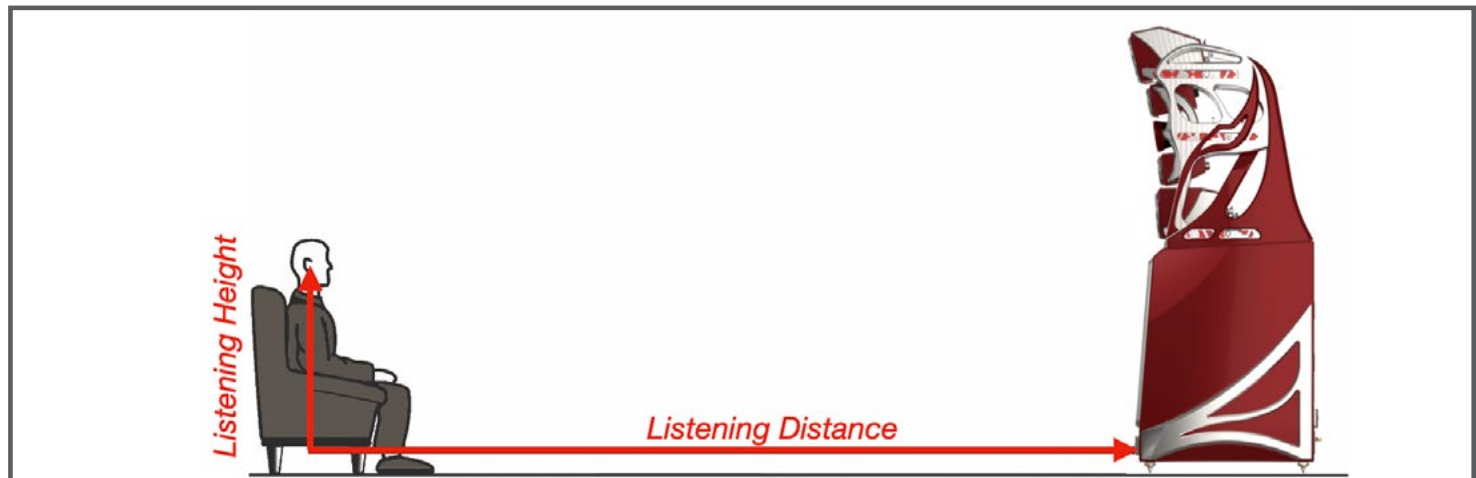

1. Refer to the Time Alignment Charts in Section 7. Time Alignment Tables for all Wilson loudspeakers are also available on the Wilson Audio's website.
2. Make sure that you are in your intended listening position.
3. While sitting, have someone measure your ear height from the floor directly below your ear canal. You should be relaxed in your chair, as you would be when listening to music. This measurement is the **Listening Height**.
4. Now measure the distance (on the floor) from the point on the floor below your ear to the base of the loudspeaker. This measurement is the **Listening Distance**.
5. Make note of the hardware settings indicated in the Nomographs for **Listening Height** and **Listening Distance** for this installation. These settings will be required when installing the Upper Modules.

SECTION 3.3—INSTALLING THE GANTRY

Note: The Autobiography Gantry is extremely heavy. Ideally, four installers should be present for the safe lifting and careful installation of the Gantry onto the Woofer enclosure.

Installing the Gantry

The Gantry is pre-assembled before shipment. The top of the Woofer enclosure features a recessed area within which the Gantry resides. Use the following steps to install the Gantry.

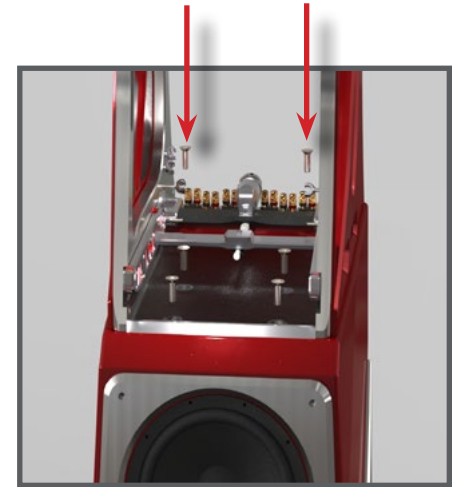

1. Lift the Gantry onto the Woofer enclosure. Take care to avoid damaging the painted surfaces as you guide the Gantry into its recessed receptacle.
2. There is intentionally a small amount of space around the edges of the Gantry within the recessed receptacle to allow for accurate installation of the Gantry. Align the six countersunk holes in the bottom plate of the Gantry with the corresponding threaded holes on the V-Material top plate of the Woofer enclosure.
3. In the Tool Kit, locate the six (*for each channel*) Gantry Harnessing Bolts.
4. Using the 5/16" Allen elbow wrench, install the six bolts securing the Gantry to the Woofer.
5. Tighten to secure, but take care not to over tighten.

Gantry

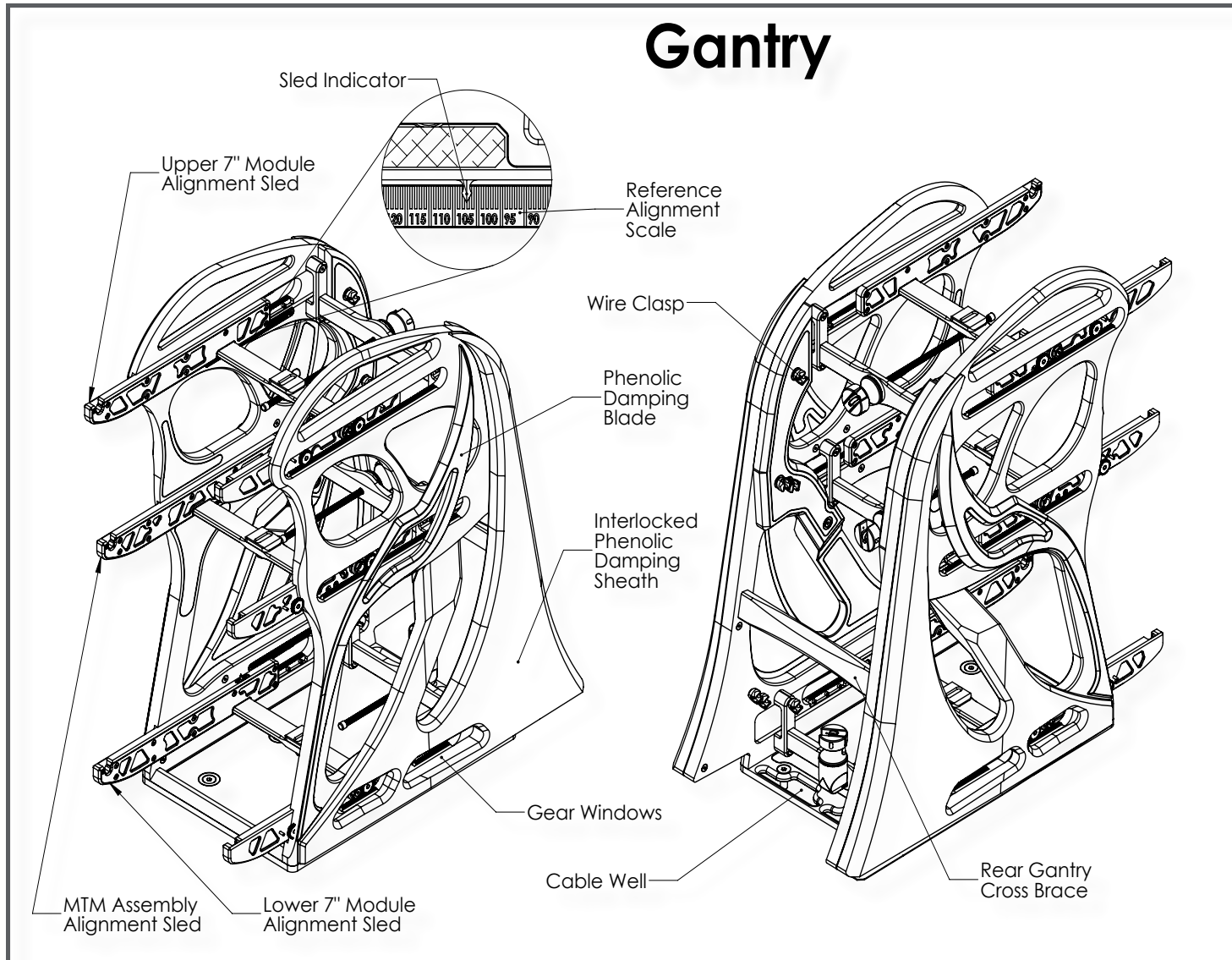

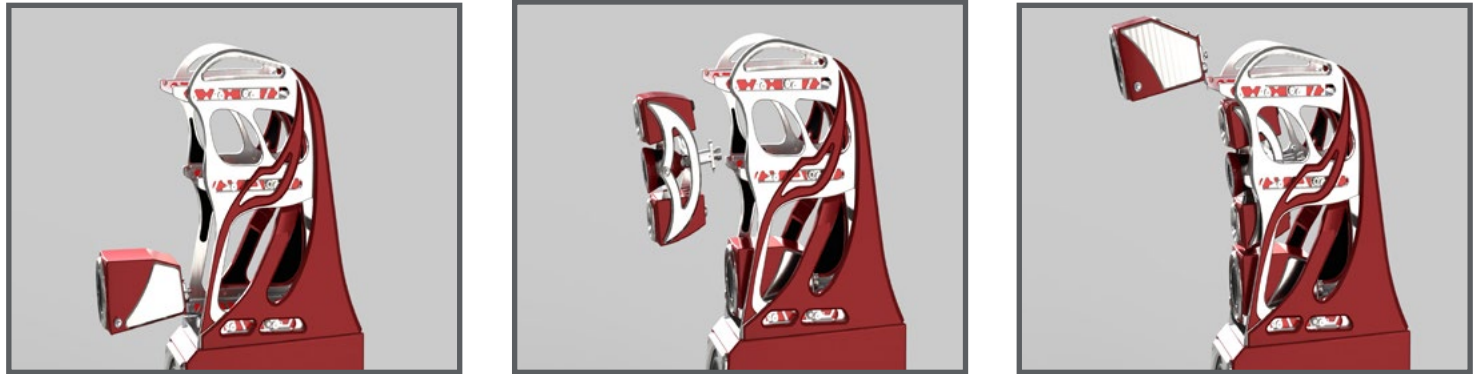

SECTION 3.4—INSTALLING THE UPPER MODULES

Note: Enlist the help of an assistant to safely install each of the three Upper Modules into the Gantry. One installer should be positioned at the rear of the Gantry to guide the Upper Modules into place and intentionally direct the cables through the Gantry while avoiding scratching any finish. The other installer should be focused on accurately setting the Module Alignment Sled Pins into the Sled Pin Cradles. Cable

Spades are shipped with protective covering, we recommend leaving this on until connecting to Binding Posts.

Note: The MTM Alignment Assembly is the heaviest of the three Upper Modules and can be awkward to handle carefully while installing into the delicately finished Gantry.

Installing the Upper Modules Into the Gantry

Note: Locate the Sealing Cable Clamp on the back of each enclosure. This hardware provides a gas-tight entry point and secures the cable. Make sure all of the Clamps are tight. The cable breaching out of the rear of the enclosure should not be moved in or out of the enclosure. Damage to the driver can occur if cables are not secured by Clamp.

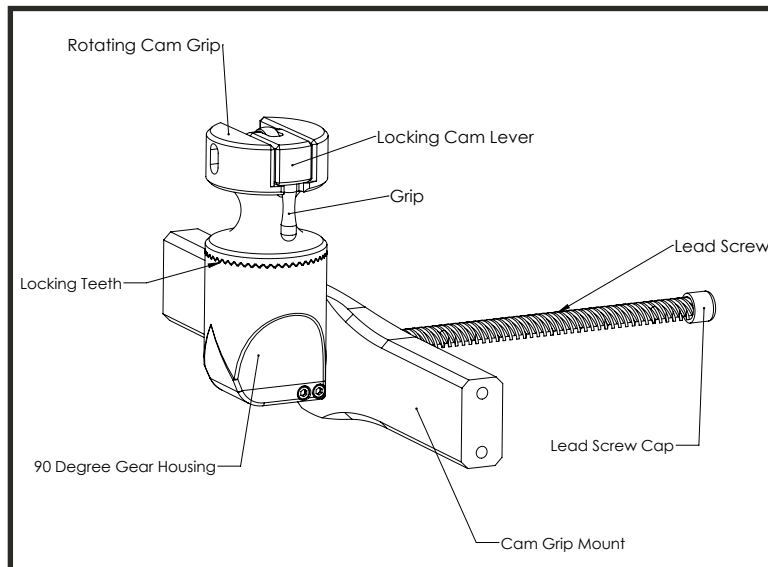

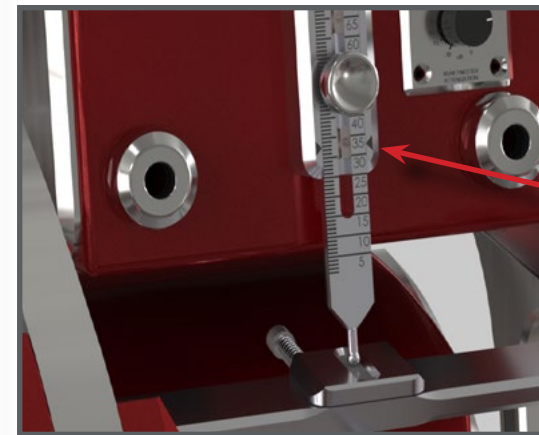
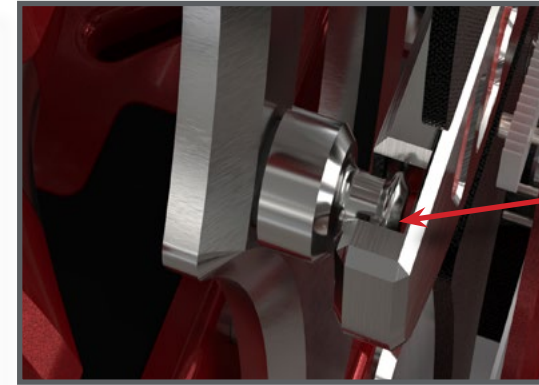
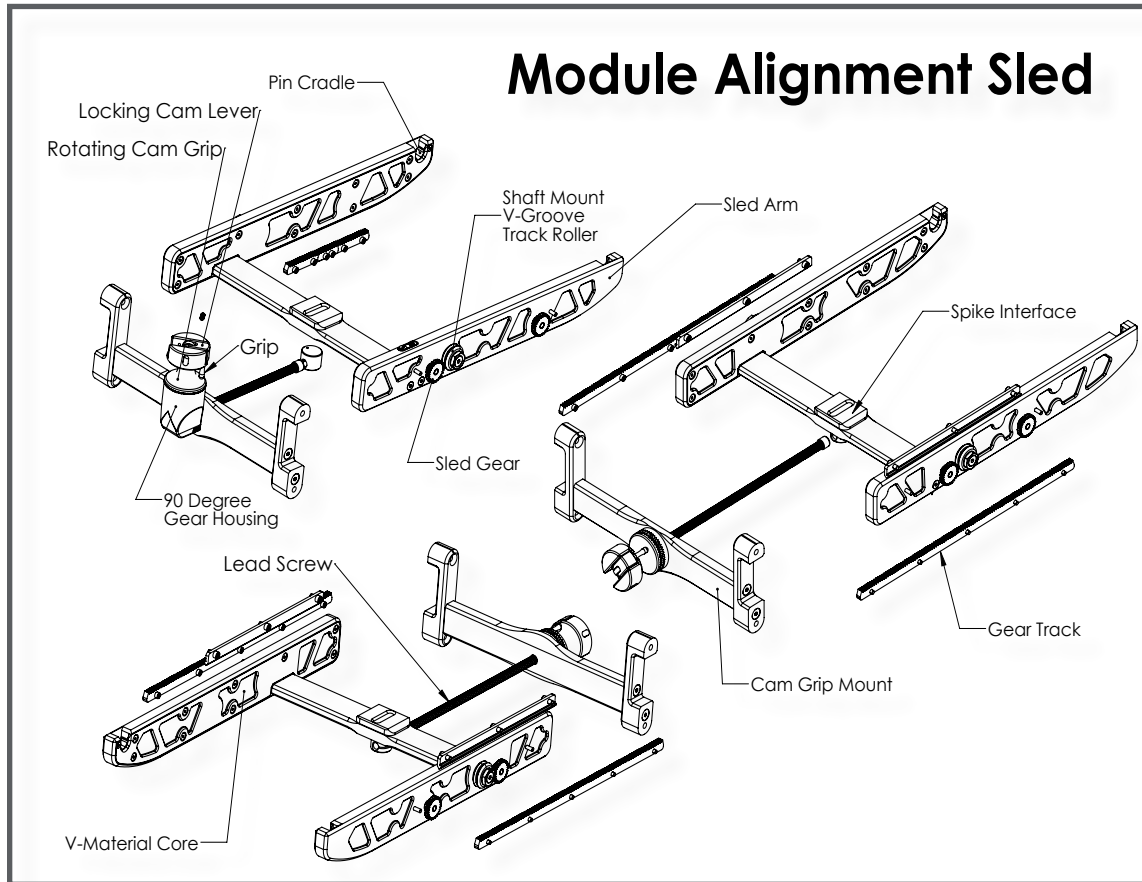

1. Locate the Rotating Cam Grip on the back of the Gantry for all three Module Alignment Sleds. Unlock all three of the Locking Cam Levers by rotating the Cam Grips out and accessible, which will allow for movement of the Sleds.
2. Move the Lower 7" Module Alignment Sled all the way forward.
3. Move the MTM Assembly Alignment Sled and the Upper 7" Module Alignment Sled all the way to the rear. This gives more room to safely install the Lower 7" Module.

4. Carefully place the Lower 7" Module, evenly spaced left to right, onto the Lower 7" Module Alignment Sled. At the center of each Slide Arm is embedded V-Material, painted Crimson Red. As you look down at the top of the Alignment Pin, make sure that it is resting in the middle of the Crimson Red V-Material. Slowly lower the rear of the enclosure until the tip of the Slide Spike is resting on the V-Material Spike Interface. Make sure that the cable is gently guided through the Gantry and accessible for the future step of connecting it to the Central Nervous System Gantry Binding Posts.
5. Using the Lower 7" Rotating Cam Grip, move the Lower 7" Module Alignment Sled to the rear of the Gantry and out of the way in preparation to installing the MTM Alignment Assembly.
6. Repeat steps 2-5 tailored to each Module to install the MTM Alignment Assembly and the Upper 7" Module.

Note: As you are moving the Alignment Sleds, while painted enclosures are installed on them, pay attention to the ends of the Lead Screw above the enclosures to ensure that the painting Modules are not inadvertently backed into the end of the Lead Screw. This has a potential of damaging the paint.

7. The next step after installing all three Upper Modules is to set the Aspherical Group Delay of the system via the Module Alignment Sled, Slide Spikes, and Tweeter Calibration Rod positions.
8. Using your measurements for Listening Height and Listening Distance, refer to the charts located in Section 7 which indicate how each Slide Spike should be adjusted. There are two reference points shown as arrows on the Slide Spike hardware. Loosen the Precision Slide-Spike Thumb Screw and move the Slide-Spike until the number listed in the Nomograph for this installation is between the arrows. Tighten the Thumb Screw.

9. After all three Slide-Spikes are set correctly, use the Rotating Cam Grip to move the Module Alignment Sled until the Sled Indicator is pointing at the correct number on the Reference Alignment Scale specified on the Nomograph.
10. Once you have properly set the Slide Spikes and Module Alignment Sleds, loosen the thumb screw above the Tweeter Calibration Rod. Move the Tweeter Calibration Rod until the number engraved on the side of the hardware is flush with the Tweeter Mount Plate. Tighten the thumb screw above the Tweeter Calibration Rod to lock in the Tweeter alignment.
11. The final step in the Upper Module alignment process is to lock the Locking Cam Lever so the cam Locking Teeth are fully engaged. Now the Module Alignment Sled will not move and the alignment settings are secure.

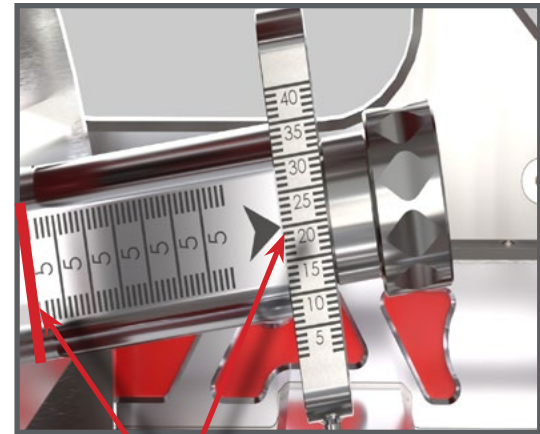

TWEETER ALIGNMENT POINTS

1. MTM PRECISION SLIDE-SPIKE
2. TWEETER CALIBRATION ROD TO TWEETER MOUNT PLATE INTERFACE

MTM Alignment Assembly

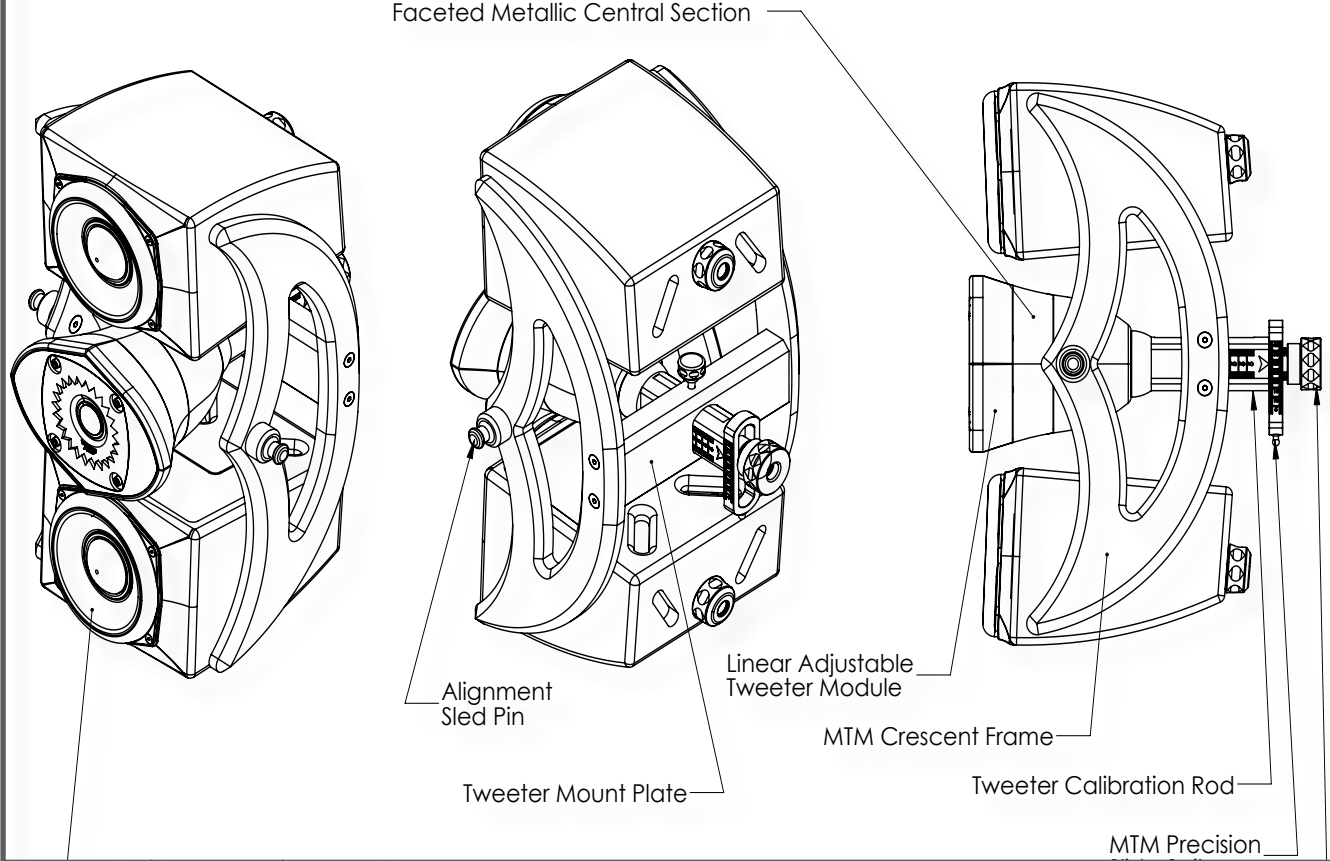

Upper 7" PentaMag™/RFT Module

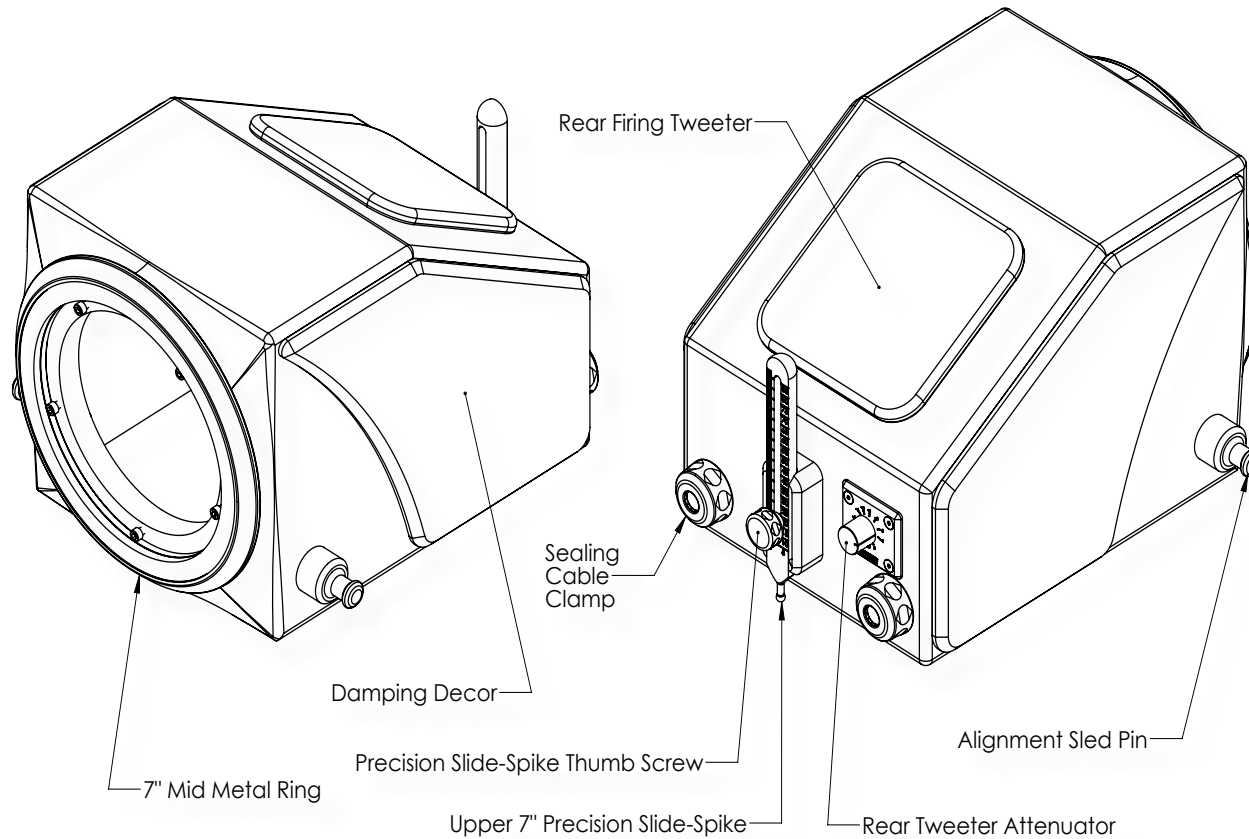

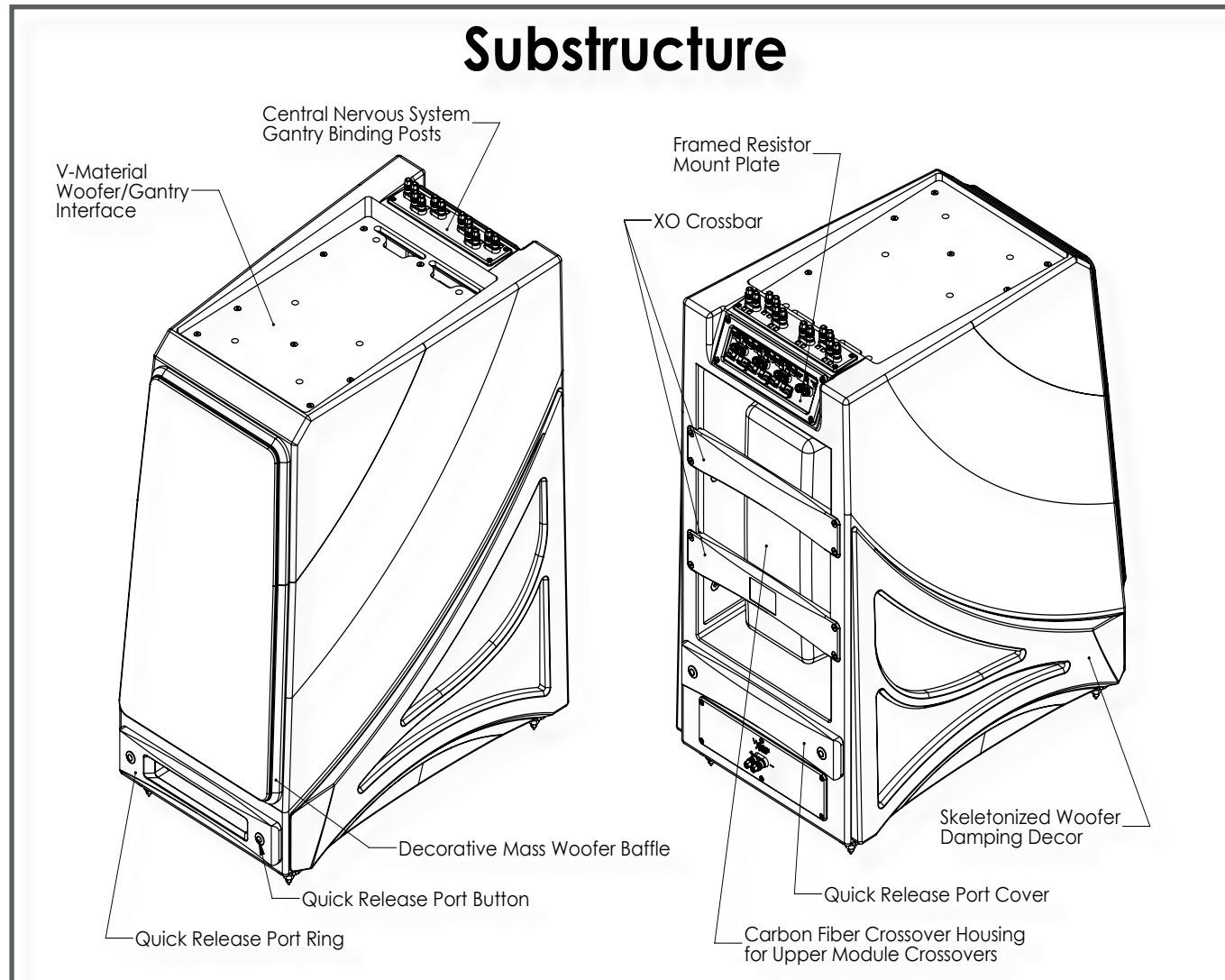

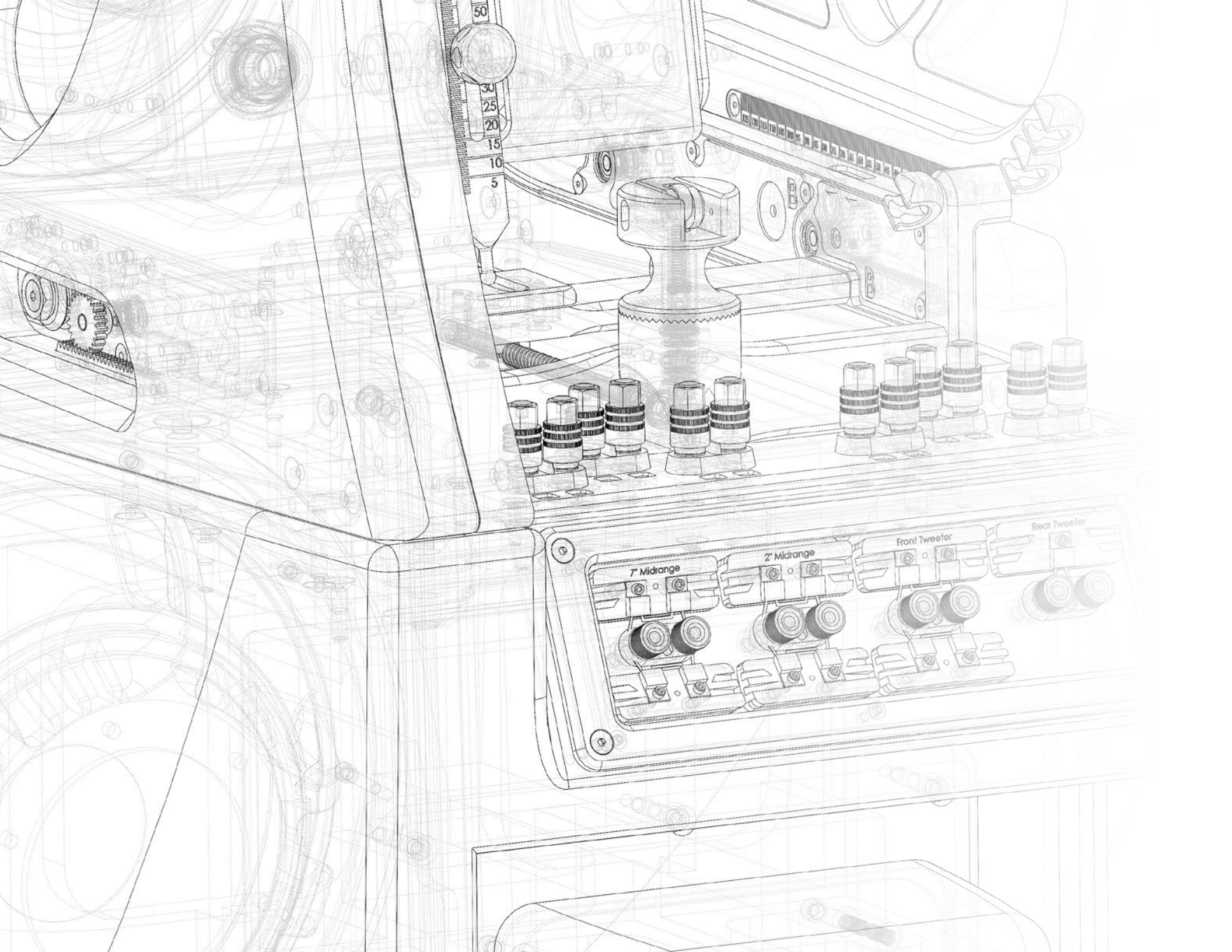

50
30
25
20
15
10
5

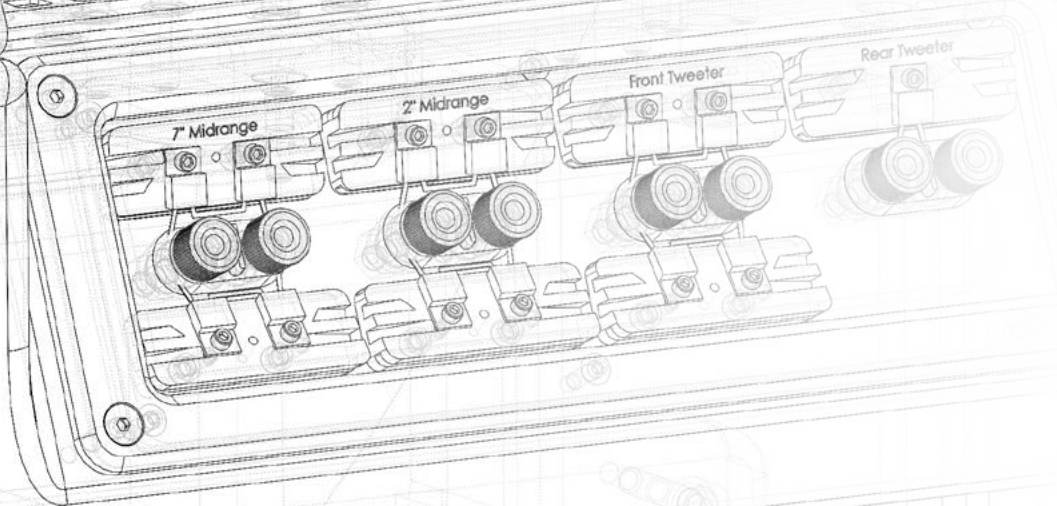
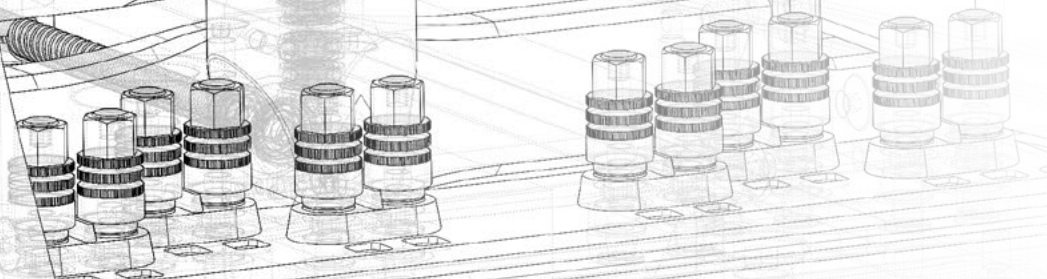

SECTION 4—CONNECTING THE MODULES

SECTION 4—CONNECTING AND DRESSING THE CABLES

The Autobiography features a series of Cable Clamps on the inside of the Gantry to provide secure and efficient dressing for the cables. The Autobiography also features new Cable Wells which allow for excess cable length to be routed out of sight. This method allows for a clean presentation of the cables and easy access to the alignment hardware.

Follow these steps to properly dress the cables.

Connecting and Dressing the Upper Module Cables

Note: It is extremely important to ensure the Sealing Cable Clamps are tightened. Failing to tighten the clamps compromises the gas-tight seal of the Module and/or damage to the driver may occur.

1. On the upper rear portion of the Woofer enclosure (Substructure), locate the connector plate (Central Nervous System) with sets of color-coded binding posts. These connectors correspond with color-coded cables attached to each Module.
2. Start by untangling and draping the cables in a way that separates the three color-coded cables that will attach to the left binding posts and the three that will connect to the right binding posts (the bubble level is in the center of the connector plate).



3. Using the connector plate as your guide, shorten the cable by routing the slack into the Cable Well such that there is just enough cable to safely and successfully connect it to its corresponding binding post.
4. After you have successfully shortened the exposed cable and the cables look organized, start attaching the cables into the Cable Clamps. This friction fit design allows for adjustment where needed to get the best look and organization of the cables.
5. Starting from left to right, connect the corresponding color-coded cables and binding posts using the 1/2" Nut Driver found in the Tool Kit. Double check and make sure the colors match as you are tighten the Binding Posts.

Note: Do not over tighten the Binding Posts, snug only.

6. Modify the cable dressing, slack, and presentation for each cable as you connect the cable to the binding post. A little cable slack is desirable for potential future micro-tuning.
7. Repeat this process for all Upper Modules until all the Upper Modules are connected for both channels.

The Autobiography is now spiked and on Sliders, in the Zone of Neutrality, all the Upper Modules are installed, time alignment settings have been locked in, the cables are all attached and dressed, and is ready for final set-up.



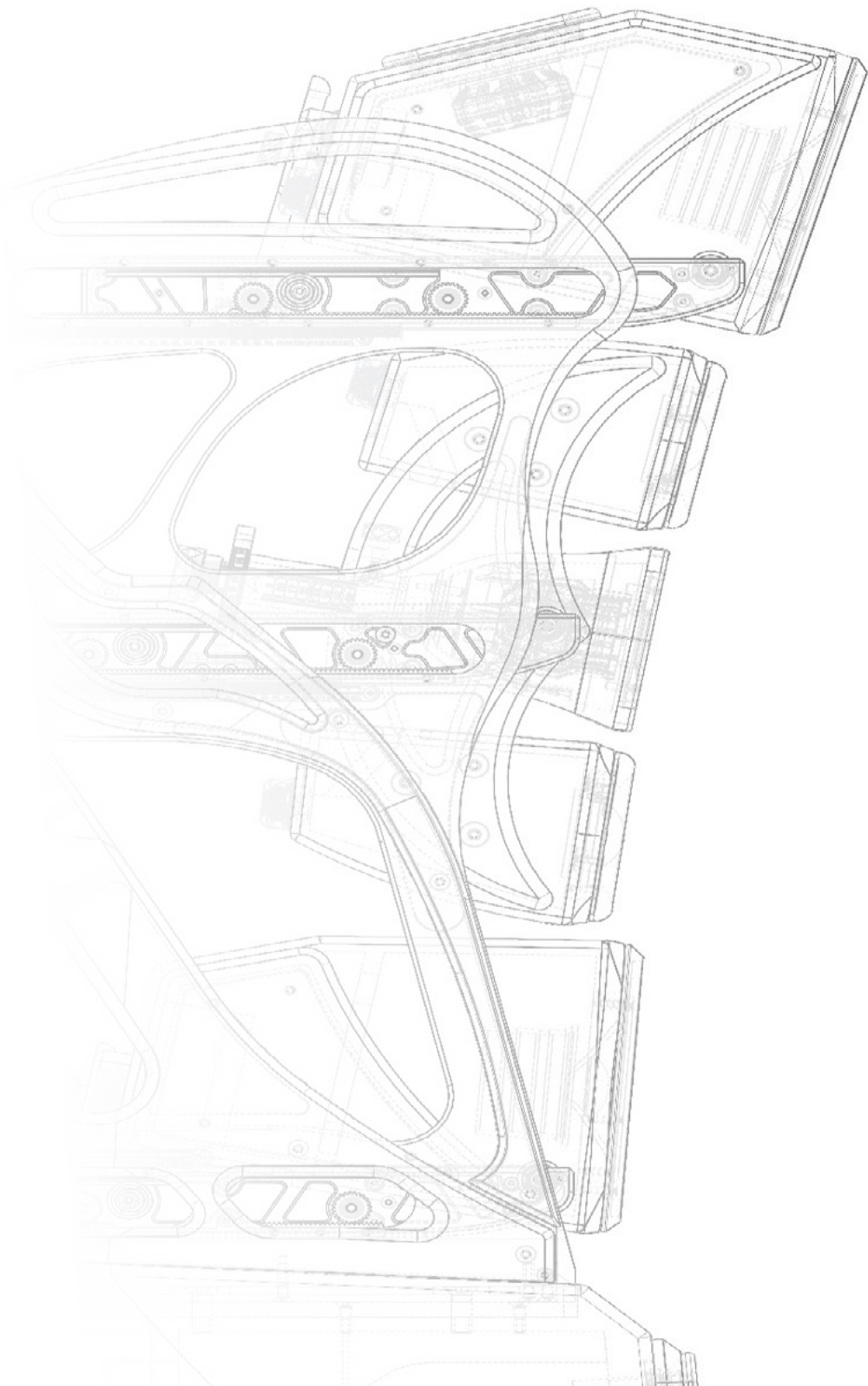

SECTION 5—FINAL SETUP

Note: Before setting up the Autobiography, please carefully study Section 1 and/or watch the WASP video linked in the same Section. These resources provide valuable information on determining the ideal room location for your speakers.

SECTION 5.1—INSTALLING AUTOBIOGRAPHY

Preparation

You will need the following items:

- Known Listening Position
- Supplied Tool Kit
- Tape Measure
- Masking Tape & Pen
- Reference Music
- Installation Calibration Form (*found on page 11*)

Connecting to your Amplifier

The Autobiography features custom-made, state-of-the-art Binding Posts to facilitate connecting Autobiography to your amplifier. Locate the 1/2" Nut Driver from your Tool Kit. Attach the main output from the amplifier to the Binding Posts located on the bottom rear of the Autobiography. Use the 1/2" Nut Driver to tighten the binding posts "snug." **Do not over-tighten.**

Listening Position

At this point the Autobiography's alignment hardware and Upper Modules should be set for the listening position of the room they are being installed in. The speakers should be toed-in for ideal driver alignment with the listener's ears and the individual should only be able to see a small amount of the inside edge of the Woofer enclosure when toe-in is correct. Completing WASP and fine-tuning at this point in the installation process should be done with music playing from this speakers.

To make correct in-home setup of Autobiography possible without test equipment, adhering to the Wilson Audio Setup Procedure (WASP) outlined in Section 1, and as shown in the instructional video we link to, is the best method with which to position your loudspeakers.

Authorized Wilson Audio Dealers are an essential and valuable resource to guide you in this setup process. All Wilson Audio Dealers are trained in the art and science of the WASP outlined in Section 1.

SECTION 5.2—ADJUSTING THE XLF PORT

Choosing a Port Configuration

All of the time alignment hardware in Autobiography can be adjusted without tools, this includes the new port hardware. The port hardware enables rapid configuration changes and room integration in a satisfying way. Adjustments can be made to the port cover and port ring by pressing the two quick release buttons, simplifying setup without sacrificing effectiveness. The Cross Load Flow (XLF) porting system has been refined to allow controlled adjustment of low frequency interaction with the listening space. In a forward firing (FF)

configuration, low frequency output in the 10 Hz to 75 Hz region is reduced by approximately 1.0 to 1.5 dB, while output between 75 Hz and 130 Hz increases by 1.5 to 2.0 dB. Switching to a rear firing (RF) configuration gives the inverse response, offering flexibility to accommodate unique room boundaries and overall listener preference.

Founded on the measured bass response of the two different port configurations, our experience suggests the following as a starting point: For inherently lossy and lean rooms, which are thus in need of additional deep bass reinforcement, the RF port configuration is recommended as a starting point. If the mid-to-upper bass is lean in your installation, the FF port configuration is probably optimal.

If your installation requires Autobiography to be installed close to the rear wall behind the speakers, start by installing the port in its FF configuration first so as to avoid potential bass overload in your room. However, if another loudspeaker has already proven to be too lean in this same location, start with the Autobiography's port in the RF configuration.

Because there are a vast number of acoustical environments into which the Autobiography will be installed, it is impossible to give absolute instructions for every given room. Each Autobiography should be evaluated in its environment, and a determination made from there.

Warning: The bass performance of Autobiography will be severely compromised if the port is not installed in one of its two configurations. Never leave both front and rear ports open at the same time.



Reversing the Port Hardware

The Autobiography ships with the port cover hardware and plug installed in the front port of the Woofer enclosure and the rear port hardware has the decorative ring attached (RF configuration). Fine-tuning the low frequency performance should be done with music playing from the speakers. To reverse the port configuration, do the following.

1. To remove the port cover and foam plug, place your thumbs against the two quick release buttons found on the port hardware and press firmly until you hear a distinct “click” from each button.
2. Carefully remove the metal cover and the foam port plug from the port space.
3. Using the same process, remove the decorative port ring from the opposite port.
4. Now follow steps 1-3 in reverse. **Don't forget to reinstall the foam port plug behind the metal port cover.**

Note: When installing the port hardware back onto the enclosure, do not press the buttons. Press firmly against the metal around the buttons until you hear a distinct “click” from each button. Expect to secure the port hardware with a bit of force.

SECTION 5.3—REAR FIRING TWEETER (RFT) ATTENUATOR

Autobiography incorporates an inverted dome Rear Firing Tweeter (RFT) designed to enhance spatial depth, ambient retrieval, and harmonic decay. This driver is constructed using aerospace grade, unidirectional spread carbon fiber, selected for its exceptional stiffness, predictability, and consistency. The diaphragm employs a variable thickness profile that minimizes inertia while maximizing structural integrity. This RFT is a wide dispersion design, optimized to reproduce ambient information without drawing attention to itself.

Its operating range spans from roughly 6 kHz to 22 kHz. The integrated RFT attenuation control allows adjustment from 0 dB to minus (-) 39.9 dB, with the maximum output setting calibrated to begin at minus (-) 7 dB at 10 kHz relative to the Front Firing Tweeter (FFT) at typical listening distances. *Try saying that five times fast.*

This flexibility enables precise tailoring to room acoustics and listener preference, providing subtle reinforcement of spatial cues and reverberant energy. The closer the RFT is to the ceiling, the more likely it is that the RFT would be attenuated.

Here is a quick reference for how much the RFT is attenuated using the numerical settings engraved on the hardware, relative to the 0 position.

Note: The 0 position on the attenuator dial is -7 dB at 10 kHz compared to the FFT:

- 0 = 0 dB** (-7.0 dB relative to the FFT)
- 2 = -1.5 dB** (-8.5 dB relative to the FFT)
- 4 = -2.5 dB** (-9.5 dB relative to the FFT)
- 6 = -3.6 dB** (-10.6 dB relative to the FFT)
- 8 = -5.3 dB** (-12.3 dB relative to the FFT)
- 10 = -7.3 dB** (-14.3 dB relative to the FFT)
- 15 = -11.9 dB** (-18.9 dB relative to the FFT)
- 30 (MAX) = -39.9 dB** (-46.9 dB relative to the FFT)

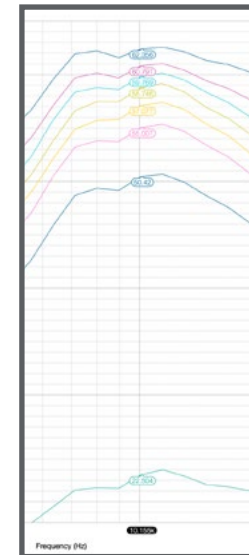

Because ceiling heights differ, as does the relative distance of the Autobiography from the rear wall and the listening position, the attenuator enables the installer to trim the output from the RFT to fit various scenarios. For installations featuring low ceilings and/or those settings where the rear of the loudspeaker is near the rear wall, the optimal setting for the RFT will likely be somewhat attenuated (-8 to -30). In those installations featuring taller ceilings and open spaces, the output of the RFT will likely be higher (0 to -8).

Listening for high-frequency ambient cues, as well as a sense of spatial sparkle, is an excellent method for evaluating the output setting that suits your room and your musical preferences. Fine-tuning the attenuator settings should be performed with music playing from the speakers.

SECTION 5.4—LEVELING AUTOBIOGRAPHY

Now that the system is calibrated to the listening space and the unique listening position it is time to remove the Sliders. Either allow the Spikes to rest directly on the floor/carpet or, to protect the flooring, rest the Spikes on the included Spike Pads. Use the Wilson Audio Jack as described on page 16 and spike the system to the floor/carpet or the Spike Pads.

Note: Before lifting Autobiography to remove the Sliders, use masking tape to carefully mark the floor around the bottom of the Woofer enclosure. By taping and marking this location you preserve the performance gained in the WASP and installation process. These reference marks can be removed once the client is satisfied with the installation.

Note: Autobiography is heavy and may seriously injure someone if tipped over. An assistant should stand to the rear of the Autobiography to steady it.

Follow these next steps to level each channel.

1. There is a precision bubble level incorporated into the Central Nervous System connector plate on the back of the Woofer enclosure. Use this tool to determine the loudspeaker's level.
2. Look at the Bubble Level on the Right channel. If the level indicates the channel is level, move to Step 4. If the bubble is not in the smallest central circle, move to Step 3.
3. To find out which spike is lowest, grasp the Autobiography enclosure and **gently** rock it back and forth. This will identify the spike that is out of level from the other three. Refer to the Bubble Level often during this process. Lengthen the appropriate spike or spikes on that lower side until the Autobiography is level.
4. When finished leveling, tighten the Spike Nut with 3/4" wrench.

Note: When finished leveling, all the Spike Nuts should be "snug" to get the best performance from the Spike & Diode assemblies. Do not over-tighten.

5. Repeat process on the other loudspeaker.

Re-check your calibrated listening position measurements (listening distance and ear height) and refer back to the Nomograph tables on page 60. Make any necessary adjustments to the hardware settings to account for the changes in distances during WASP. Sometimes there are no changes needed.



SECTION 5.5—REMOVING THE PROTECTIVE FILM

To protect the finish of Autobiography during manufacturing, shipment, and setup in your listening room, we have applied a removable layer of protective film over the paint finish. We recommend that this film be left in place until the speakers are ready to be assembled at their final location. Once you have determined their final position, remove the film by following this procedure:

1. Ensure the speaker surface is room temperature before removing the protective film.

Note: Removing the protective film when the speaker surface is cold can damage the paint surface.

2. Slowly remove the film from the top of the enclosure down, large sections at a time, gently pulling the film downward and outward.

Note: Tearing the film quickly and aggressively can damage the paint.

3. Take care while removing the protective film near edges and corners to prevent paint damage in these areas.
4. The protective film should not be left on the painted surface for extended periods of time, nor exposed to heat sources and/or direct sunlight, as this will likely damage the paint.

SECTION 5.6—RESISTORS

Found on the back of the upper bevel Woofer enclosure is the Resistor Access Panel. These resistors serve several functions. These specialized resistors not only serve as a type of fuse to protect Autobiography's drivers, they can also be used as tools for tuning the system in rare cases.

Note: Only Wilson Audio replacement resistors should be used in Autobiography. Changing the value or brand of resistor will have a potentially negative effect on the sonic performance of your loudspeakers and can void your Warranty.

Replacing a Resistor

Make sure the power amplifier(s) are turned OFF before replacing the resistor(s). The resistors are designed in such a way that most of the time they will open before irreversible damage occurs to the corresponding driver. In some rare cases both the drivers and resistors are damaged.

7" Midrange, 2" Midrange, and Front Tweeter Resistors

The **7" Midrange** resistors equal 0.1 ohms (4 X 0.1Ω in series/parallel). The **2" Midrange** resistors equal 7.1 ohms (4 X 7.1Ω in series/parallel). The **Front Tweeter** resistors equal 3.2 ohms (4 X 3.2Ω in series/parallel). The **Rear Tweeter** resistor will never need to be changed.

Resistors provide precise level matching between the Midranges and Tweeter. The resistors also act as ultra-high-quality fuses which open before a driver can be damaged by excess power (i.e. power surges, blackouts, clipping, etc.). The hardware associated with the resistors are designed such that replacing the resistors do not require tools. Make sure the correct value resistors are being installed during the replacement process.

Woofers Damping Resistor

There is a single 18.6 ohm barrel damping resistor for



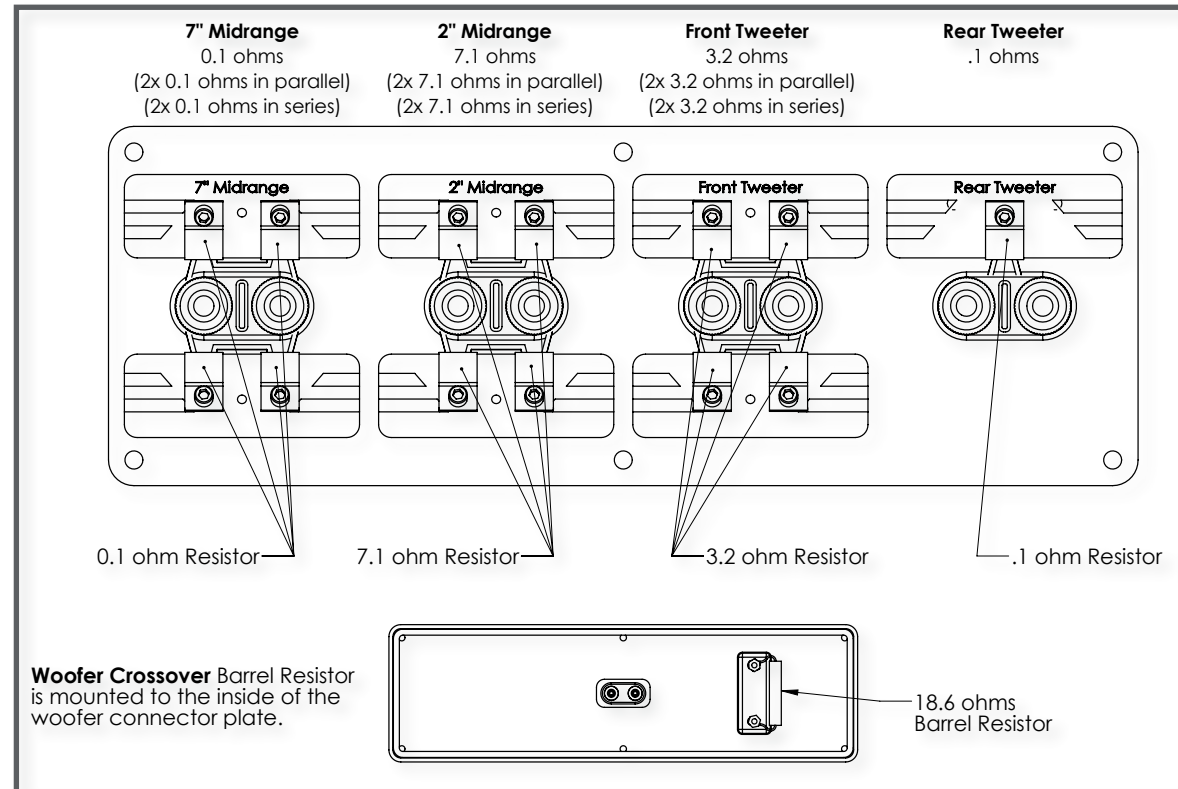

the Woofer. This resistor is preinstalled on the back of the Main In connector plate of the Autobiography and should not be changed by the end user.

Resistor Fine Tuning

In some very rare instances, it may be desirable to alter the levels of the Tweeter or Midrange to overcome some room related tonal balance issues. As a last resort, please contact your authorized Wilson Audio Dealer for help and more information on how to proceed.

Note: These specialized resistors can be ordered from your authorized Wilson Audio Dealer or on the Wilson Audio Online Store. Only use Wilson Audio replacement resistors in Autobiography.

Note: If you notice the sonic qualities of your system degraded or worsen, you may have resistors that are damaged. These resistors don't always "open up" like fuses and can continue to pass a signal when damaged. This is most commonly attributed to sudden surges in the system from blackouts, clipping, or "pops" associated with disconnecting cables without muting the amps. Please replace the resistors as soon as possible to bring the performance and life back into your system.

Autobiography represents a culmination of engineering vision and artisanal mastery. Designed around an advanced analog alignment system that delivers extraordinary temporal precision, it stands as the leader of what is possible in loudspeaker time domain accuracy. More than 1,800 bespoke and precision elements are integrated within a structure rich with proprietary hardware and extraordinary materials including X-Material, V-Material, H-Material, carbon fiber, aerospace grade aluminum, pure copper, gold, and much more. Each component is carefully handled by skilled craftspeople, reflecting a disciplined, multi-generational tradition of meticulous assembly and refinement. The result is a loudspeaker of uncommon mechanical integrity, deep emotional connection, and musical fidelity. Every surface, interface, and structural point is designed and created to serve a purpose in the faithful reproduction of recorded sound. Handcrafted in Provo, Utah, United States of America, Autobiography embodies Wilson Audio's enduring standards and culture of Excellence in All Things, truly a tireless pursuit of musical truth. Thank you for including this special state-of-the-art loudspeaker in your home.



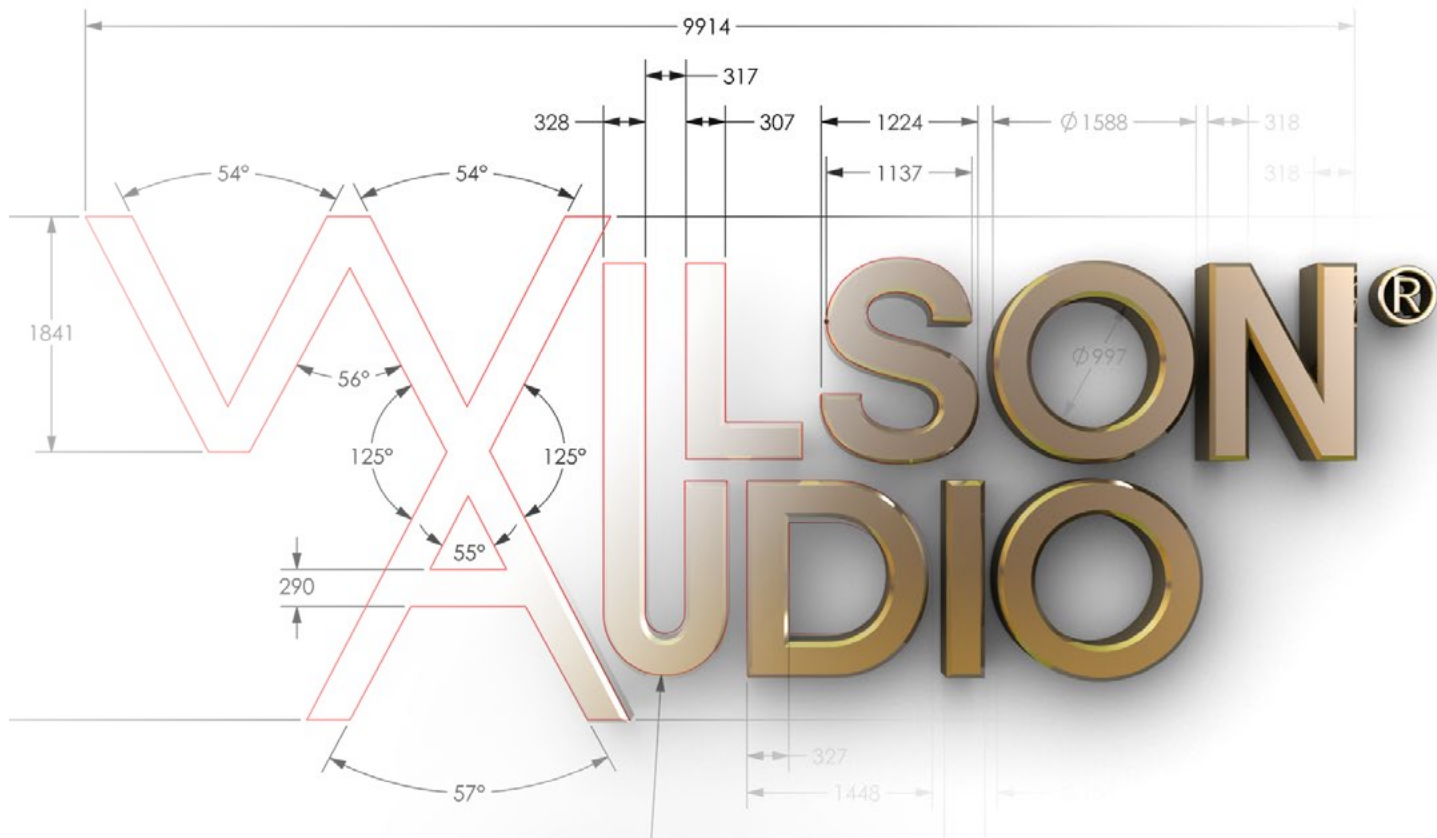

SECTION 6—SPECIFICATIONS

SECTION 6.1—SPECIFICATIONS

Enclosure Type Woofer: Adjustable Port, Rear or Front Firing

Enclosure Type 7" Midrange: Bottom Vented (Two Modules)

Enclosure Type 2" Midrange: Rear Vented (Two Modules)

Enclosure Type Tweeter: Sealed

Woofers: One—15 inch (38.10 cm) *Hard Paper Pulp*

One—12 inch (30.48 cm) *Hard Paper Pulp*

Midrange: Two—7 inch (17.78 cm) *Paper Pulp*

Two—2 inch (5.08 cm) *Doped Fabric*

Front Tweeter: One—1 inch (2.54 cm) *Doped Silk Fabric, Dome*

Rear Tweeter: One—1 inch (2.54 cm) *Unidirectional Carbon Fiber, Inverted Dome*

Sensitivity: 89.5 dB @ 1 Watt @ 1 Meter @ 1 kHz

Nominal Impedance: 4 ohms / Minimum 2.1 ohms @ 293 Hz

Minimum Amplifier Power: 100 Watts Per Channel

Frequency Response: 18 Hz – 36 kHz +/- 2 dB, *Room Average Response [RAR]*

Overall Dimensions: Height—83 $\frac{7}{16}$ inch (212 cm) *w/ Spikes [Variable]*

Width—21 $\frac{1}{2}$ inch (55 cm)

Depth—34 $\frac{7}{8}$ inch (89 cm)

System Weight Per Channel: 821 lb (372.40 kg)

Approximate Total Shipping Weight: 2,335 lb (1,059.14 kg)

SECTION 6.2—GRAPHICAL DIMENSIONS

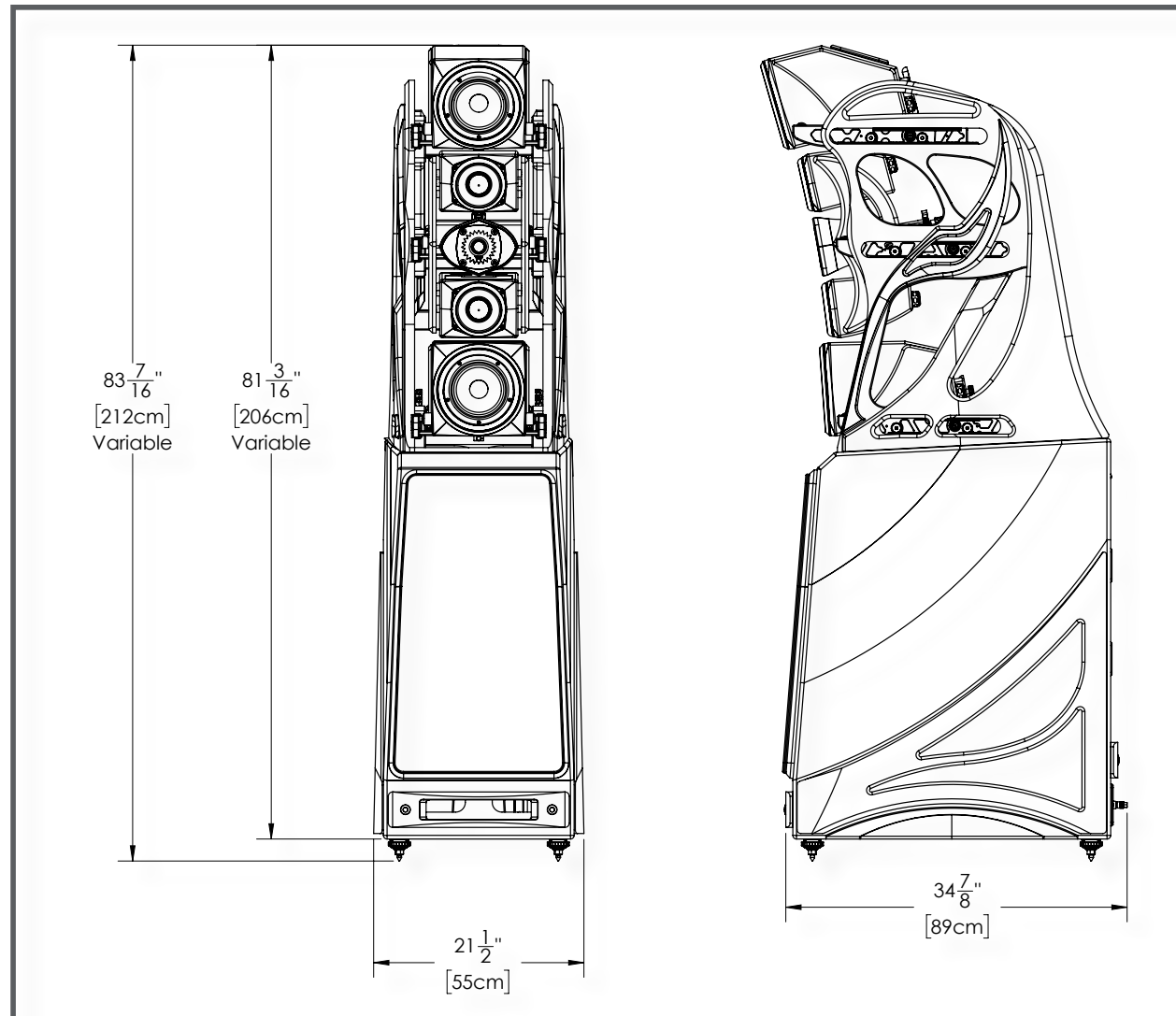

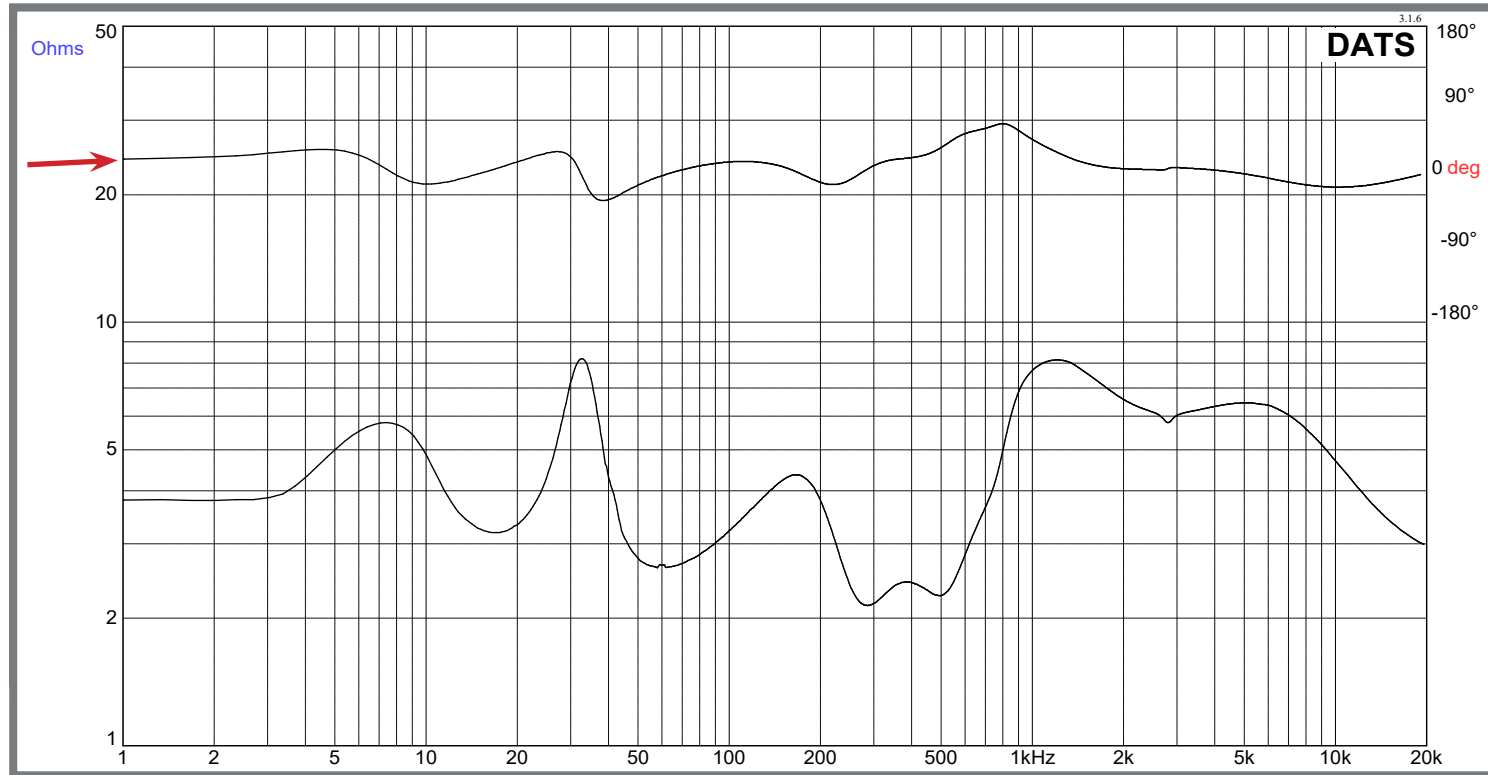

SECTION 6.3—AUTOBIOGRAPHY PHASE CURVE

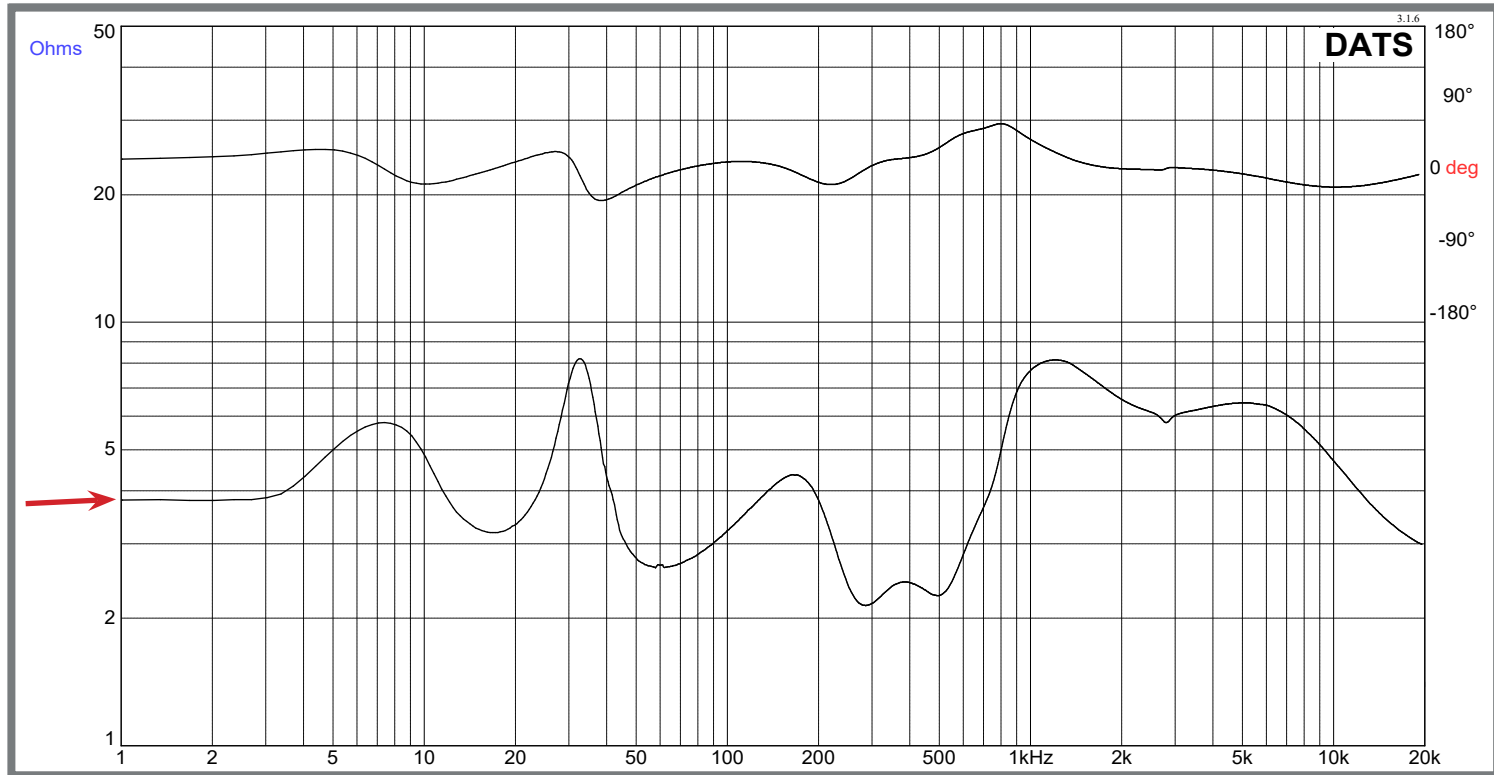

SECTION 6.4—AUTOBIOGRAPHY IMPEDANCE CURVE

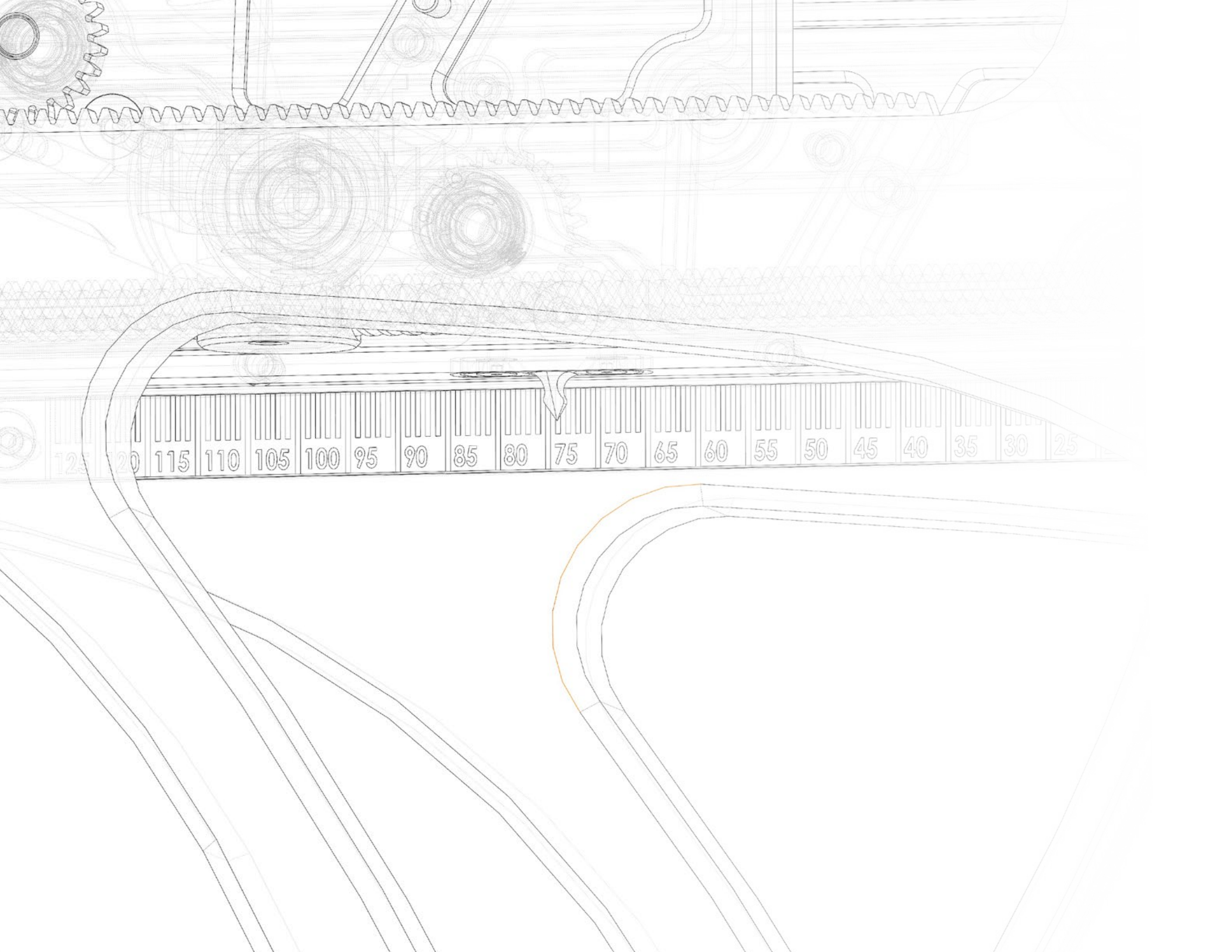

SECTION 7—TIME ALIGNMENT CHARTS

Autobiography Lower 7" Alignment Sled Position

Ear Height		Listening Distance														
		8 ft	9 ft	10 ft	11 ft	12 ft	13 ft	14 ft	15 ft	16 ft	17 ft	18 ft	19 ft	20 ft	22 ft	24 ft
		2.44 m	2.74 m	3.05 m	3.35 m	3.66 m	3.96 m	4.27 m	4.57 m	4.88 m	5.18 m	5.49 m	5.79 m	6.1 m	6.71 m	7.32 m
48 in	122 cm	24.5	29	32.5	35.5	38	40	42	43.5	45	46.5	47.5	48.5	49.5	51	52.5
47 in	119.5 cm	27.5	31.5	35	38	40	42	44	45.5	47	48	49	50	51	52.5	53.5
46 in	117 cm	30.5	34.5	37.5	40.5	42.5	44	46	47.5	48.5	49.5	50.5	51.5	52	53.5	54.5
45 in	114.5 cm	34	37.5	40.5	42.5	44.5	46.5	47.5	49	50	51	52	53	53.5	54.5	56
44 in	112 cm	37	40.5	43	45	46.5	48.5	49.5	51	51.5	52.5	53.5	54	55	56	57
43 in	109 cm	40.5	43	45.5	47.5	49	50.5	51.5	52.5	53.5	54	55	55.5	56	57	58
42 in	106.5 cm	43.5	46	48	50	51	52.5	53.5	54.5	55	56	56.5	57	57.5	58.5	59
41 in	104 cm	47	49	50.5	52	53.5	54.5	55.5	56	56.5	57.5	58	58.5	59	59.5	60
40 in	101.5 cm	50	52	53.5	54.5	55.5	56.5	57.5	58	58.5	59	59.5	60	60	61	61.5
39 in	99 cm	53	55	56	57	58	68.5	59	59.5	60	60.5	61	61	61.5	62	62.5
38 in	96.5 cm	57.5	57.5	58.5	59.5	60	60.5	61	61.5	61.5	62	62.5	62.5	63	63.5	63.5
37 in	94 cm	60	60.5	61	61.5	62	62.5	63	63.5	63.5	63.5	64	64	64	64.5	65
36 in	91.5 cm	‡	63.5	64	64	64.5	64.5	65	65	65	65	65.5	65.5	65.5	65.5	66
35 in	89 cm	‡	66.5	66.5	66.5	66.5	66.5	66.5	66.5	66.5	67	67.5	67	67	67	67
34 in	86.5 cm	‡	‡	‡	69	68.5	68.5	68.5	68.5	68.5	68.5	68.5	68	68	68	68

‡ Please contact your dealer for set-up information.

Autobiography Lower 7" Slide-Spike

Ear Height		Listening Distance														
		8 ft	9 ft	10 ft	11 ft	12 ft	13 ft	14 ft	15 ft	16 ft	17 ft	18 ft	19 ft	20 ft	22 ft	24 ft
		2.44 m	2.74 m	3.05 m	3.35 m	3.66 m	3.96 m	4.27 m	4.57 m	4.88 m	5.18 m	5.49 m	5.79 m	6.1 m	6.71 m	7.32 m
48 in	122 cm	7	7	7	6.5	6.5	6.5	6.5	6.5	6.5	6.5	6.5	6.5	6.5	6.5	6.5
47 in	119.5 cm	9	8.5	8.5	8.5	8	8	8	7.5	7.5	7.5	7.5	7.5	7.5	7.5	7
46 in	117 cm	11	10.5	10	9.5	9.5	9.5	9	9	8.5	8.5	8.5	8.5	8	8	8
45 in	114.5 cm	13	12	11.5	11	11	10.5	10	10	9.5	9.5	9.5	9	9	9	8.5
44 in	112 cm	15	14	13.5	12.5	12	11.5	11.5	11	10.5	10.5	10	10	10	9.5	9
43 in	109 cm	17	16	15	14	13.5	13	12.5	12	12	11.5	11	11	10.5	10.5	10
42 in	106.5 cm	19	17.5	16.5	15.5	15	14.5	13.5	13.5	13	12.5	12	12	11.5	11	10.5
41 in	104 cm	21	19.5	18	17	16.5	15.5	15	14.5	14	13.5	13	12.5	12.5	12	11.5
40 in	101.5 cm	23	21.5	20	18.5	17.5	17	16	15.5	15	14.5	14	13.5	13	12.5	12
39 in	99 cm	25	23	21.5	20.5	19	18	18.5	16.5	16	15.5	15	14.5	14	13.5	13
38 in	96.5 cm	27.5	25	23	21.5	20.5	19.5	18.5	17.5	17	16.5	16	15.5	15	14	13.5
37 in	94 cm	29.5	27	25	23.5	22	21	19.5	19	18	17.5	17	16.5	16	15	14
36 in	91.5 cm	‡	29	26.5	25	23.5	22	21	20	19	18.5	17.5	17	16.5	15.5	15
35 in	89 cm	‡	31	28.5	26.5	25.5	23.5	22	21	20	19.5	18.5	18	17.5	16.5	15.5
34 in	86.5 cm	‡	‡	‡	28	26	24.5	23.5	22.5	21.5	20.5	19.5	19	18.5	17	16.5

‡ Please contact your dealer for set-up information.

Autobiography MTM Assembly Alignment Sled Position

Ear Height		Listening Distance														
		8 ft	9 ft	10 ft	11 ft	12 ft	13 ft	14 ft	15 ft	16 ft	17 ft	18 ft	19 ft	20 ft	22 ft	24 ft
		2.44 m	2.74 m	3.05 m	3.35 m	3.66 m	3.96 m	4.27 m	4.57 m	4.88 m	5.18 m	5.49 m	5.79 m	6.1 m	6.71 m	7.32 m
48 in	122 cm	6.5	9	10.5	12.5	13.5	14.5	15.5	16.5	17	18	18.5	19	19.5	20	21
47 in	119.5 cm	12.5	14	15.5	16.5	17.5	18.5	19	20	20	21	21	21.5	22	22.5	23
46 in	117 cm	18.5	19.5	20.5	21	22	22.5	23	23	23.5	24	24	24	24.5	24.5	25
45 in	114.5 cm	24.5	25	25.5	25.5	26	26	26.5	26.5	26.5	26.5	26.5	27	27	27	27
44 in	112 cm	30.5	30.5	30	30	30	30	30	30	29.5	29.5	29.5	29.5	29.5	29.5	29
43 in	109 cm	37	36	35	34.5	34	34	33.5	33	33	32.5	32	32	29.5	31.5	31
42 in	106.5 cm	43	41.5	40	39	38.5	37.5	37	36.5	36	35.5	35	35	32	34	33.5
41 in	104 cm	49	47	45	43.5	42.5	41.5	40.5	40	39	38.5	38	37.5	34.5	36	35.5
40 in	101.5 cm	55	52.5	50	48	46.5	41.5	44	43	42	42	40.5	40	39.5	38.5	37.5
39 in	99 cm	61	58	55	52.5	50.5	49	47.5	46.5	45	45.5	43.5	43	42	41	40
38 in	96.5 cm	67.5	63.5	60	57.5	55	53	51	50	48.5	47	46	45	44.5	43	42
37 in	94 cm	73.5	69	65	61.5	59	57	55	53	51.5	50	49	48	47	45.5	44
36 in	91.5 cm	‡	74.5	70	66.5	63.5	60.5	58.5	56.5	55	53	52	50.5	49.5	47.5	46
35 in	89 cm	‡	80	75	71	67.5	64.5	62	60	58	56	54.5	53	52	50	48
34 in	86.5 cm	‡	‡	‡	75	71.5	68.5	65.5	63	61	59	57.5	56	54.5	52	50

"‡" Please contact your dealer for set-up information.

Autobiography MTM Slide-Spike

Ear Height		Listening Distance														
		8 ft	9 ft	10 ft	11 ft	12 ft	13 ft	14 ft	15 ft	16 ft	17 ft	18 ft	19 ft	20 ft	22 ft	24 ft
		2.44 m	2.74 m	3.05 m	3.35 m	3.66 m	3.96 m	4.27 m	4.57 m	4.88 m	5.18 m	5.49 m	5.79 m	6.1 m	6.71 m	7.32 m
48 in	122 cm	19.5	17	15.5	14	13	12	11	10	9.5	9	8.5	8	7.5	6.5	6
47 in	119.5 cm	21	18.5	16.5	15	13.5	12.5	11.5	11	10	9.5	9	8.5	8	7	6.5
46 in	117 cm	22	19.5	17.5	16	14.5	13.5	12.5	11.5	11	10	9.5	9	8.5	7.5	7
45 in	114.5 cm	23.5	21	19	17	15.5	14.5	13.5	12.5	11.5	11	10	9.5	9	8	7.5
44 in	112 cm	25	22.5	20	18	16.5	15	14	13	12	11.5	11	10	9.5	8.5	8
43 in	109 cm	26.5	23.5	21	19	17.5	16	15	14	13	12	11.5	11	10	9	8.5
42 in	106.5 cm	28	25	22.5	20.5	18.5	17	15.5	14.5	13.5	13	12	11.5	11	9.5	9
41 in	104 cm	29.5	26	23.5	21.5	19.5	18	16.5	15.5	14.5	13.5	12.5	12	11.5	10	9
40 in	101.5 cm	31	27.5	25	22.5	20.5	19	17.5	16	15	14	13.5	12.5	12	10.5	9.5
39 in	99 cm	32.5	29	26	23.5	21.5	19.5	18	17	16	15	14	13	12.5	11	10
38 in	96.5 cm	34	30	27	24.5	22.5	20.5	19	17.5	16.5	15.5	14.5	14	13	11.5	10.5
37 in	94 cm	36	31.5	28.5	25.5	23.5	21.5	20	18.5	17.5	16	15	14.5	13.5	12.5	11
36 in	91.5 cm	‡	33	29.5	27	24.5	22.5	20.5	19	18	17	16	15	14	13	11.5
35 in	89 cm	‡	34.5	30.5	28	25.5	23.5	21.5	20	18.5	17.5	16.5	15.5	15	13.5	12
34 in	86.5 cm	‡	‡	‡	29	26.5	24	22.5	21	19.5	18	17	16	15.5	14	12.5

"‡" Please contact your dealer for set-up information.

Autobiography Upper 7" Alignment Sled Position

Ear Height		Listening Distance														
		8 ft	9 ft	10 ft	11 ft	12 ft	13 ft	14 ft	15 ft	16 ft	17 ft	18 ft	19 ft	20 ft	22 ft	24 ft
		2.44 m	2.74 m	3.05 m	3.35 m	3.66 m	3.96 m	4.27 m	4.57 m	4.88 m	5.18 m	5.49 m	5.79 m	6.1 m	6.71 m	7.32 m
48 in	122 cm	18	16.5	15.5	14.5	13.5	13	12.5	12	11.5	11	11	10.5	10	10	9.5
47 in	119.5 cm	26	23.5	22	20.5	19	18	17	16.5	15.5	15	14.5	14	13.5	13	12
46 in	117 cm	34	31	28.5	26.5	24.5	23	22	20.5	20	19	18	17.5	17	15.5	15
45 in	114.5 cm	42	38	35	32	30	28	26.5	25	24	23	22	21	20	19	17.5
44 in	112 cm	50	45.5	41.5	38	35.5	33	31	29.5	28	26.5	25.5	24	23.5	22	20.5
43 in	109 cm	58.5	52.5	48	44	41	38	36	34	32	30.5	29	28	26.5	25	23
42 in	106.5 cm	67	60	54.5	50	46.5	43	40.5	38	36	34.5	33	31	30	28	26
41 in	104 cm	75	67	61	56	52	48.5	45	42.5	40	38	36.5	35	33	31	28.5
40 in	101.5 cm	83.5	74.5	68	62	57.5	53.5	50	47	44.5	42	40	38	36.5	34	31.5
39 in	99 cm	92	82	74.5	68	63	58.5	55	51.5	48.5	46	44	42	40	37	34
38 in	96.5 cm	100	89.5	81	74.5	68.5	63.5	59.5	56	52.5	50	47.5	45	43	40	37
37 in	94 cm	108.5	97	88	80.5	74	68.5	64	60	57	54	51	48.5	46.5	43	39.5
36 in	91.5 cm	‡	104.5	94.5	86.5	79.5	74	69	64.5	61	57.5	55	52	50	46	42.5
35 in	89 cm	‡	112	101	92.5	85	79	73.5	69	65	61.5	58.5	55.5	53	49	45
34 in	86.5 cm	‡	‡	‡	98.5	91.5	84	78.5	73.5	69	65.5	62	59	56.5	52	48

"‡" Please contact your dealer for set-up information.

Autobiography Upper 7" Slide-Spike

Ear Height		Listening Distance														
		8 ft	9 ft	10 ft	11 ft	12 ft	13 ft	14 ft	15 ft	16 ft	17 ft	18 ft	19 ft	20 ft	22 ft	24 ft
		2.44 m	2.74 m	3.05 m	3.35 m	3.66 m	3.96 m	4.27 m	4.57 m	4.88 m	5.18 m	5.49 m	5.79 m	6.1 m	6.71 m	7.32 m
48 in	122 cm	42	35.5	30.5	26.5	23.5	20.5	18	16	14	12.5	11	9.5	8.5	6	4.5
47 in	119.5 cm	44	37.5	32.5	28	24.5	21.5	19	17	15	13	11.5	10.5	9	7	5
46 in	117 cm	46	39.5	34	29.5	26	23	20	18	16	14	12.5	11	10	7.5	6
45 in	114.5 cm	48.5	41.5	36	31.5	27.5	24	21.5	19	17	15	13.5	12	10.5	8.5	6.5
44 in	112 cm	50.5	43.5	37.5	32.5	29	25.5	22.5	20	18	16	14.5	13	11.5	9	7
43 in	109 cm	53	45.5	39	34.5	30	26.5	24	21	19	17	15	13.5	12	10	8
42 in	106.5 cm	55.5	47.5	41	36	31.5	28	25	22.5	20	18	16	14.5	13	10.5	8.5
41 in	104 cm	57.5	49.5	43	37.5	33	29.5	26	23.5	21	19	17	15.5	14	11.5	9
40 in	101.5 cm	60	51.5	44.5	39	34.5	30.5	27.5	24.5	22	20	18	16	14.5	12	10
39 in	99 cm	62.5	53.5	46.5	40.5	36	32	28.5	25.5	23	21	19	17	15.5	12.5	10.5
38 in	96.5 cm	65	55.5	48	42.5	37.5	33	29.5	26.5	24	22	20	18	16.5	13.5	11
37 in	94 cm	67.5	57.5	50	43.5	38.5	34.5	31	28	25	23	21.5	19	17	14	12
36 in	91.5 cm	‡	59.5	51.5	45.5	40	36	32	29	26	23.5	21.5	19.5	18	15	12.5
35 in	89 cm	‡	62	53.5	47	41.5	37	33.5	30	27	24.5	22.5	20.5	18.5	15.5	13
34 in	86.5 cm	‡	‡	‡	48.5	43	38.5	34.5	31	28	25.5	23.5	21.5	19.5	16.5	14

"‡" Please contact your dealer for set-up information.

Autobiography Tweeter Calibration Rod Position

Ear Height		Listening Distance														
		8 ft	9 ft	10 ft	11 ft	12 ft	13 ft	14 ft	15 ft	16 ft	17 ft	18 ft	19 ft	20 ft	22 ft	24 ft
		2.44 m	2.74 m	3.05 m	3.35 m	3.66 m	3.96 m	4.27 m	4.57 m	4.88 m	5.18 m	5.49 m	5.79 m	6.1 m	6.71 m	7.32 m
48 in	122 cm	36.5	36	36	35.5	35.5	35.5	35	35	35	35	35	34.5	34.5	34.5	34.5
47 in	119.5 cm	36.5	36	36	35.5	35.5	35.5	35	35	35	35	35	34.5	34.5	34.5	34.5
46 in	117 cm	36.5	36	36	35.5	35.5	35.5	35	35	35	35	35	34.5	34.5	34.5	34.5
45 in	114.5 cm	36.5	36	36	35.5	35.5	35.5	35	35	35	35	35	34.5	34.5	34.5	34.5
44 in	112 cm	36.5	36	36	35.5	35.5	35.5	35	35	35	35	35	34.5	34.5	34.5	34.5
43 in	109 cm	36.5	36	36	35.5	35.5	35.5	35	35	35	35	35	34.5	34.5	34.5	34.5
42 in	106.5 cm	36.5	36	36	35.5	35.5	35.5	35	35	35	35	35	34.5	34.5	34.5	34.5
41 in	104 cm	36.5	36	36	35.5	35.5	35.5	35	35	35	35	35	34.5	34.5	34.5	34.5
40 in	101.5 cm	36.5	36	36	35.5	35.5	35.5	35	35	35	35	35	34.5	34.5	34.5	34.5
39 in	99 cm	36.5	36	36	35.5	35.5	35.5	35	35	35	35	35	34.5	34.5	34.5	34.5
38 in	96.5 cm	36.5	36	36	35.5	35.5	35.5	35	35	35	35	35	34.5	34.5	34.5	34.5
37 in	94 cm	36.5	36	36	35.5	35.5	35.5	35	35	35	35	35	34.5	34.5	34.5	34.5
36 in	91.5 cm	‡	36	36	35.5	35.5	35.5	35	35	35	35	35	34.5	34.5	34.5	34.5
35 in	89 cm	‡	36	36	35.5	35.5	35.5	35	35	35	35	35	34.5	34.5	34.5	34.5
34 in	86.5 cm	‡	‡	‡	35.5	35.5	35.5	35	35	35	35	35	34.5	34.5	34.5	34.5

"‡" Please contact your dealer for set-up information.

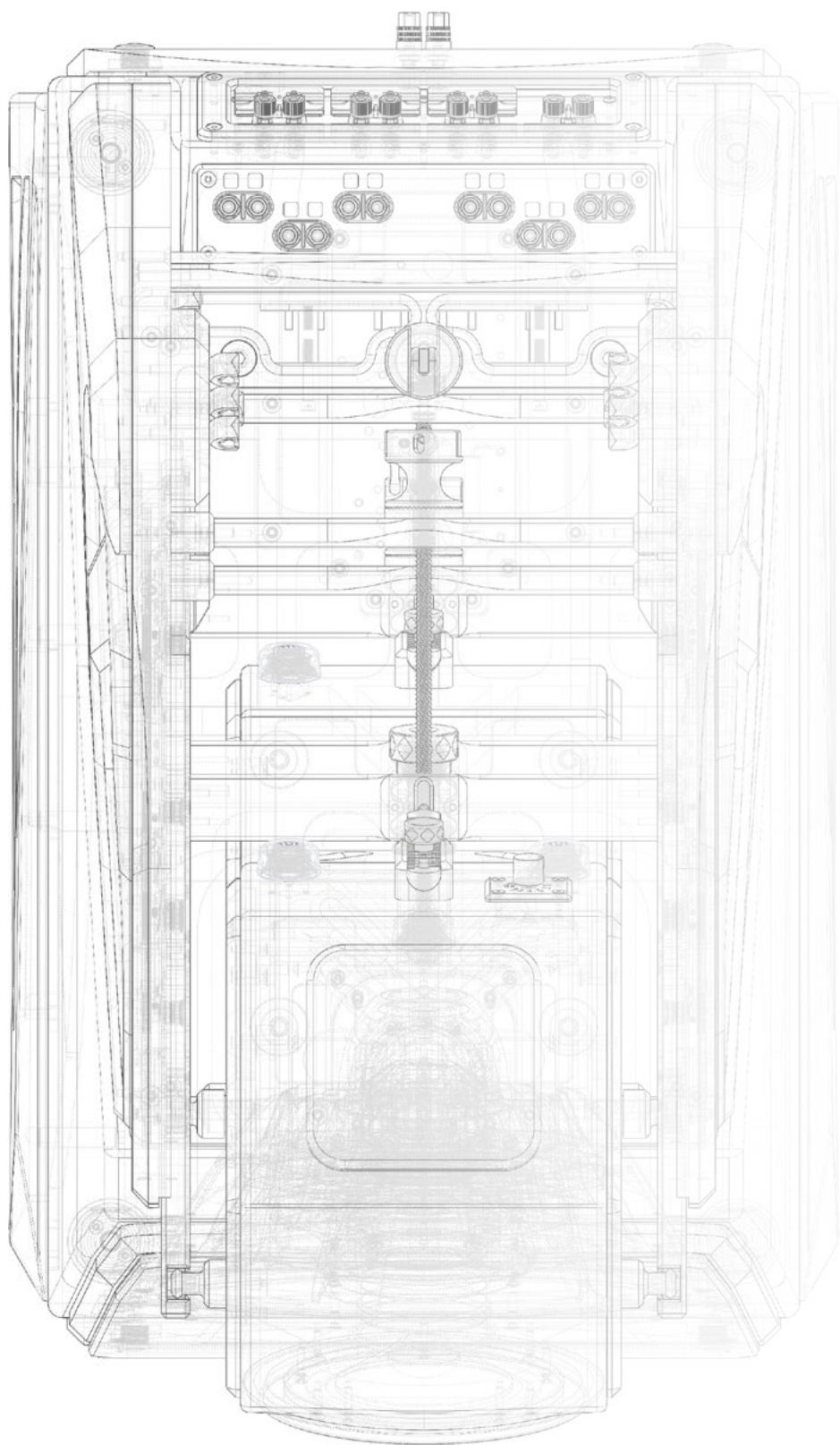

SECTION 8—WARRANTY

SECTION 8—WARRANTY DETAILS

Limited Warranty

Subject to the conditions set forth herein, Wilson Audio warrants its electronics to be free of manufacturing defects in material and workmanship for the Warranty Period. The Warranty Period is a period of 90 days from the date of purchase by the original purchaser, or if both of the following two requirements are met, the Warranty Period is a period of five (5) years from the date of purchase by the original purchaser:

Requirement No. 1. No later than 30 days after product delivery to the customer, the customer must have returned the Warranty Registration Form to Wilson Audio. Alternatively, the warranty may be filled out on Wilson Audio's website.

Requirement No. 2. The product must have been professionally installed by the Wilson Audio Dealer that sold the product to the customer.

FAILURE TO COMPLY WITH EITHER REQUIREMENT NO. 1 OR REQUIREMENT NO. 2 WILL RESULT IN THE WARRANTY PERIOD BEING LIMITED TO A PERIOD OF 90 DAYS ONLY.

Conditions

This Limited Warranty is also subject to the following conditions and limitations. The Limited Warranty is void and inapplicable if the product has been used or handled other than in accordance with the instructions in the owner's manual, or has been abused or misused, damaged by accident or neglect or in being transported, or if the product has been tampered with or service or repair of the product has been attempted or performed by anyone other than Wilson Audio, an authorized Wilson Audio Dealer Technician or a service or repair center authorized by Wilson Audio to service or repair the product. Contact Wilson Audio at 1(801) 377-2233 for information on location of Wilson Audio Dealers and authorized service and repair centers. Most repairs can be made in the field. In instances where return to Wilson Audio's factory is required, the Dealer or customer must first obtain a return authorization. Purchaser must pay for shipping to Wilson Audio, and Wilson Audio will pay for shipping of its choice to return the product to purchaser. A RETURNED PRODUCT MUST BE ACCOMPANIED BY A WRITTEN DESCRIPTION OF THE DEFECT. Wilson Audio reserves the right to modify the design of any product without obligation to purchasers of previously manufactured products and to change the prices or specifications of any product without notice or obligation to any person.

Remedy

In the event that the product fails to meet the above Limited Warranty and the conditions set forth herein have been met, the purchaser's sole remedy under this Limited Warranty shall be to: (1) contact an authorized Wilson Audio Dealer within the Warranty Period for service or repair of the product without charge for parts or labor, which service or repair, at the Dealer's option, shall take place either at the location where the product is installed or at the Dealer's place of business; or (2) if purchaser has timely sought service or repair and the product cannot be serviced or repaired by the Dealer, then purchaser may obtain a return authorization from Wilson Audio and at purchaser's expense return the product to Wilson Audio where the defect will be rectified without charge for parts or labor.

Warranty Limited to Original Purchaser

This Limited Warranty is for the sole benefit of the original purchaser of the covered product and shall not be transferred to a subsequent purchaser of the product, unless the product is purchased by the subsequent purchaser from an authorized Wilson Audio Dealer who has certified the product in accordance with Wilson Audio standards and requirements and the certification has been accepted by Wilson Audio, in which event the Limited Warranty for the product so purchased and certified shall expire at the end of the original Warranty Period applicable to the product.

Demonstration Equipment

Equipment, while used by an authorized Dealer for demonstration purposes, is warranted to be free of manufacturing defects in materials and workmanship for a period of five (5) years from the date of shipment to the Dealer. Demo equipment needing warranty service may be repaired on-site or, if necessary, correctly packed and returned to Wilson Audio by the Dealer at Dealer's sole expense. Wilson Audio will pay return freight of its choice. A returned product must be accompanied by a written description of the defect. Dealer owned demonstration equipment sold at retail within two (2) years of date of shipment to the Dealer is warranted to the first retail customer to be free of manufacturing defects in materials and workmanship for the same time periods as if the product had originally been bought for immediate resale to the retail customer. Wilson Audio products are warranted for a period of 90 days, unless extended to 5 years, as provided above, by return and filing of completed Warranty Registration at Wilson Audio within 30 days after product delivery to customer and the product was professionally installed by the Wilson Audio Dealer that sold the product to the customer.

Miscellaneous

ALL EXPRESS AND IMPLIED WARRANTIES NOT PROVIDED FOR HEREIN ARE HEREBY EXPRESSLY DISCLAIMED. ANY LEGALLY IMPOSED IMPLIED WARRANTIES RELATING TO THE PRODUCT SHALL BE LIMITED TO THE DURATION OF THIS LIMITED WARRANTY. THIS LIMITED WARRANTY DOES NOT EXTEND TO ANY INCIDENTAL OR CONSEQUENTIAL COSTS OR DAMAGES TO THE PURCHASER.

Some States in the United States of America do not allow limitations on how long an implied warranty lasts or an exclusion or limitation of incidental or consequential damages, so the above limitations or exclusions may not apply to you. This Limited Warranty gives you specific legal rights, and you may also have other rights, which vary from state to state.



- Replacement Resistors
- Books and Literature
- Custom Loudspeaker Covers
- Installation Tools and Accessories
- New Grilles and Diffraction Blankets
- WilsonGloss Care Products and Kits
- Wilson Audio Signature Apparel
- Upgrade Spikes and Binding Posts
- . . . And More

Visit our Service Channel on YouTube to View How-To Videos



PARTS STORE



SERVICE CHANNEL



WWW.WILSONAUDIO.COM

WILSON AUDIO

2233 MOUNTAIN VISTA LANE

PROVO, UTAH 84606

UNITED STATES OF AMERICA